

July 2014

# West Sacramento General Reevaluation Report



**US Army Corps  
of Engineers**®  
Sacramento District



**Draft Report  
Documentation  
Civil Design Appendix**



**Cover Photo: Sacramento River, West Sacramento, and Yolo Bypass, March 2011**

**Photo courtesy of Chris Austin.**

**WEST SACRAMENTO PROJECT, CALIFORNIA  
GENERAL REEVALUATION REPORT**

**Draft Report Documentation**

**Civil Design Appendix**

**U.S. Army Corps of Engineers  
Sacramento District**

**July 2014**

This page intentionally left blank.

**WEST SACRAMENTO PROJECT, CALIFORNIA  
GENERAL REEVALUATION REPORT**

**Civil Design Appendix**

**TABLE OF CONTENTS**

<b>1 - INTRODUCTION.....</b>	<b>1-3</b>
1.1 PROJECT LOCATION AND BACKGROUND.....	1-3
1.2 COORDINATION .....	1-4
<b>2 - GENERAL DESIGN CONSIDERATIONS .....</b>	<b>2-1</b>
2.1 TOPOGRAPHIC DATA.....	2-1
2.2 DATUM.....	2-1
2.3 LEVEE GEOMETRY .....	2-1
2.4 ALIGNMENTS AND STATIONING .....	2-1
2.5 LEVEE HEIGHT .....	2-2
2.6 LEVEE DEFICIENCIES.....	2-2
2.7 RELOCATIONS AND UTILITIES .....	2-3
2.8 CONSTRUCTION ACCESS, HAUL ROUTES, AND STAGING AREAS .....	2-3
2.9 REAL ESTATE REQUIREMENTS .....	2-3
2.10 OPERATION AND MAINTENANCE .....	2-4
<b>3 - PROJECT DESIGN FEATURES AND ALTERNATIVES.....</b>	<b>3-5</b>
3.1 ALTERNATIVES .....	3-5
3.2 CONSTRUCTION DURATION.....	3-9
3.3 CIVIL ESTIMATES .....	3-12
3.4 RELOCATIONS.....	3-13
<b>ATTACHMENT 1 - FIGURES.....</b>	<b>ATT1-1</b>
<b>ATTACHMENT 2 - PLATES .....</b>	<b>ATT2-1</b>

**LIST OF TABLES**

TABLE 1: REACH DEFICIENCIES.....	1-2
TABLE 2: ALTERNATIVE 1 – PROPOSED FEATURES.....	3-6
TABLE 3: ALTERNATIVE 3 – PROPOSED FEATURES.....	3-8
TABLE 4: ALTERNATIVE 5 – PROPOSED FEATURES.....	3-9
TABLE 5: ALTERNATIVE 1 – MINIMUM YEARS TO CONSTRUCT .....	3-10
TABLE 6: ALTERNATIVE 3 – MINIMUM YEARS TO CONSTRUCT .....	3-11
TABLE 7: ALTERNATIVE 5 – MINIMUM YEARS TO CONSTRUCT .....	3-12

---

**LIST OF FIGURES**

FIGURE 1: PROJECT LOCATION.....	1-3
FIGURE 2: TYPICAL FLOODWALL SECTION .....	ATT1-2
FIGURE 3: TYPICAL LEVEE SECTION.....	ATT1-2
FIGURE 4: LEVEE IMPROVEMENTS WITH SLURRY WALL .....	ATT1-3
FIGURE 5: SLURRY WALL AND LANDSIDE SLOPE IMPROVEMENT .....	ATT1-3
FIGURE 6: LEVEE LANDSIDE SLOPE IMPROVEMENT .....	ATT1-4
FIGURE 7: EMBANKMENT FILL AND STABILITY BERM.....	ATT1-4
FIGURE 8: EMBANKMENT FILL & RELIEF WELL .....	ATT1-5
FIGURE 9: EMBANKMENT FILL AND SHEET PILE WALL .....	ATT1-5
FIGURE 10: EROSION PROTECTION PLAN .....	ATT1-6
FIGURE 11: BANK EROSION PROTECTION.....	ATT1-6
FIGURE 12: DWSC CLOSURE STRUCTURE PLAN .....	ATT1-7
FIGURE 13: TYPICAL CROSS SECTION FIX-IN-PLACE .....	ATT1-7
FIGURE 14: TYPICAL CROSS SECTION STRENGTHEN IN-PLACE WITH CUTOFF WALL.....	ATT1-8
FIGURE 15: TYPICAL CROSS SECTION – ADJACENT LEVEE WITH CUTOFF WALL.....	ATT1-8
FIGURE 17: SETBACK LEVEE WITH SEEPAGE BERM.....	ATT1-9
FIGURE 18: SETBACK LEVEE WITH CUTOFF WALL.....	ATT1-10
FIGURE 19: SETBACK LEVEE WITH SEEPAGE BERM.....	ATT1-10
FIGURE 20: SETBACK LEVEE WITH SEEPAGE BERM.....	ATT1-11
FIGURE 21: ADJACENT LEVEE WITH CUTOFF WALL .....	ATT1-11

# 1 - INTRODUCTION

This appendix documents the civil design for the West Sacramento Project General Reevaluation Report (West Sacramento GRR). The purpose of the West Sacramento GRR is to evaluate the additional levee improvements and measures necessary to reduce flood risk to the City of West Sacramento. The study area includes the Sacramento River, Yolo Bypass, and Deep Water Ship Channel. This appendix will summarize the design and site considerations required for construction of project features, access roads, staging areas, real estate requirements, relocations and quantities developed for the alternatives analyzed for the West Sacramento GRR. Design consideration information includes floodwall and levee construction guidance, EM-1110-2-1913 Design and Construction of Levees, ER 1110-2-1150 Engineering and Design for Civil Works Projects.

## 1.1 PROJECT LOCATION AND BACKGROUND

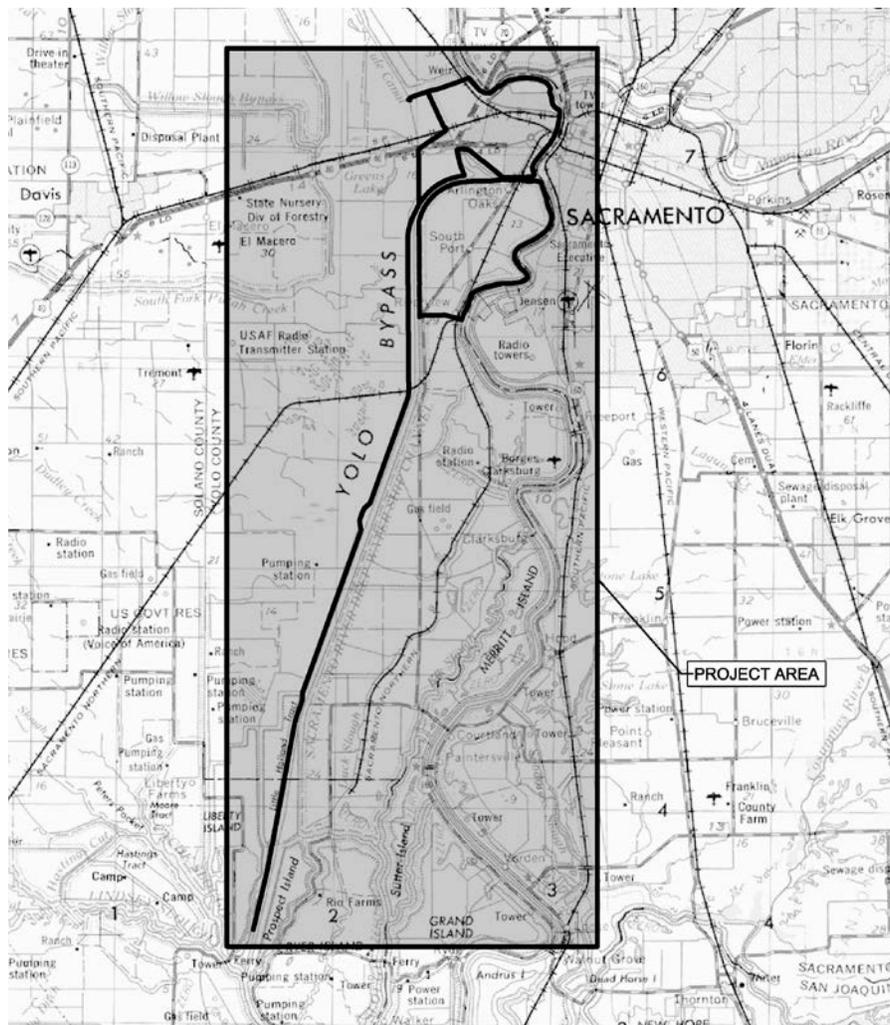

Figure 1: Project Location

The West Sacramento GRR project area includes approximately 50 miles of levee and approximately corresponds with the city limits for the City of West Sacramento. The project area is bound by the Yolo Bypass to the west, the Sacramento Bypass to the north, and the Sacramento River to the east. Additionally, the Deep Water Ship Channel (DWSC) divides the project area into the North and South Basin. The project area has been split into nine reaches for technical evaluation. A description of the levee reaches is below:

- **Sacramento River North Levee** extends for approximately 5.5 miles along the Sacramento River right bank levee from the Sacramento Bypass south to the confluence of the Barge Canal and the Sacramento River.
- **Sacramento Bypass Levee** extends for approximately 1.1 miles along the Sacramento Bypass left bank levee from the Sacramento Weir west to the Yolo Bypass Levee.
- **Yolo Bypass Levee** extends for approximately 3.7 miles along the Yolo Bypass levee left bank from the confluence of the Sacramento Bypass and the Yolo Bypass south to the Navigation Levee (DWSC West).
- **Port North** extends for approximately 4.9 miles along the DWSC right bank from the Barge Canal west to the bend in the Navigation Levee.
- **Port South Levee** extends for approximately 4 miles along the DWSC left bank levee from the Barge Canal west past the bend in the DWSC.
- **DWSC West** extends for approximately 21.4 miles along the DWSC right bank levee from the bend in the DWSC at the intersection of Port North Levee and Yolo Bypass Levee south to Miners Slough.
- **DWSC East** extends for approximately 2.8 miles along the DWSC left bank levee from the end of Port South Levee south to South Cross Levee.
- **Sacramento River South Levee** extends approximately 5.9 miles along the Sacramento River right bank levee from the confluence of the Barge Canal and the Sacramento River south to the South Cross Levee.
- **South Cross Levee** extends along the South Cross levee for approximately 1.2 miles from Jefferson Boulevard to the Sacramento River where it intersects the southern end of Sacramento River South Levee.

## 1.2 COORDINATION

The project development team consisted of USACE Sacramento District. Additionally, USACE New Orleans District provided design assistance to the Sacramento District. Non-USACE team members include the State of California, City of West Sacramento and West Sacramento Area Flood Control Agency (WSAFCA).

## 2 - GENERAL DESIGN CONSIDERATIONS

### 2.1 TOPOGRAPHIC DATA

The topographic data used for civil design alternative quantity estimates were based on Light Detection and Ranging (LiDAR) surveys conducted in 2007. The surveyed area consisted of a larger survey contract through the DWR in support of its Urban Levee Evaluation (ULE) geotechnical evaluations.

Bathymetry data along the Sacramento River was also used in conjunction with the LiDAR surveys for Sacramento River North and Stone Lock. Bathymetric data was collected using post processed kinematic GPS for vertical and horizontal positioning of soundings.

### 2.2 DATUM

All horizontal and vertical coordinates of position from survey are presented in Universal Transverse Mercator (UTM), measured in feet, using the North American Datum of 1983 (NAD83). Horizontal coordinates were converted to the California State Plane Zone II coordinate system by Corpscon. All GPS derived elevations are referenced to North American Vertical Datum of 1988 (NAVD88). All elevations provided herein are relative to the NAVD88 vertical datum and NAD83 horizontal datum.

### 2.3 LEVEE GEOMETRY

Acceptable levee geometry was established by the Sacramento District's Geotechnical Section and their Standards of Practice. Levee geometry associated with a Fix In-Place method consisted of:

- Levee Crown of 20 feet
- Waterside Slope of 3H:1V
- Landside Slope of 3H:1V

New levee construction would require flatter levee slopes of 3H:1V for increased levee safety and stability. A comprehensive evaluation of performance deficiencies, including cross section analysis, geology and geomorphology, foundation conditions, and geotechnical risk and uncertainty analyses are found in the Geotechnical Appendix.

### 2.4 ALIGNMENTS AND STATIONING

Levee stationing in feet was developed for each feature for design purposes and quantity take-offs for purposes of this report. Alignments for existing levee improvements were determined by the existing features such as existing levee crown, landside or waterside toe, etc.

The landside toe was determined using the LiDAR data and recent aerial photos and was visually located by USACE Sacramento District Civil Design. Most of the access-related improvements were developed using offsets of this approximation.

## 2.5 LEVEL HEIGHT

In order to meet the state criteria of a 200-year Annual Exceedance Probability (AEP) plus 3 feet, levee crown profile for alternative selection was chosen as the design profile for the GRR project. In areas where the existing ground was higher than the criteria, that segment of ground was used for the design profile. The water surface data came from the modeling efforts of the Sacramento District Hydraulics Section.

## 2.6 LEVEL DEFICIENCIES

Within the study area, the geotechnical deficiencies of the levees were identified and grouped in the following categories:

- Seepage – Through seepage and underseepage
- Stability – Oversteepened slopes, typically less than 2H:1V
- Height – Levee overtopping
- Erosion – Highly erodible soils, significant scour and velocity issues

Table 1 describes levee deficiencies for each reach.

**Table 1: Reach Deficiencies**

REACH	REACH LENGTH FEET	FEATURE LENGTH FEET	IMPROVEMENT
Sacramento Bypass	6,478	-	None
Yolo Bypass	19,749	2,500	Seepage, Stability
		1,900	Seepage
DWSC West Levee	100,260	9,000	Seepage, Height
		7,000	Seepage, Height
		9,000	Seepage, Height
		75,260	Height
		99,010	Erosion
DWSC East Levee	17,171	1,500	Seepage
		7,055	Seepage
		5,945	Seepage
		2,671	Height
Port North	23,225	8,245	Height
		14,170	Height
Port South	16,262	15,560	Height
		1,000	Seepage
South Cross Levee	6,273	1,100	Stability, Height
		5,000	Seepage, Height
Sacramento River North Levee	30,700	30000	Erosion
		11,080	Seepage
		1,470	Seepage
		500	Seepage
		5,530	Seepage
Sacramento River South Levee	33,100	4,600	Height
		33,100	Seepage, Erosion
Sacramento Bypass Training Dike	3,000	3,000	Erosion Protection

## 2.7 RELOCATIONS AND UTILITIES

Relocations were based upon the work previously done by HDR, the Sacramento District Levee Safety section periodic inspection reports, and existing levee logs maintained by the Department of Water Resources. Many of the items were available in GIS and for the pump stations and various power poles the locations were mapped. If the levee height was increased, we assumed that pumps and pipes would be replaced. In addition, the City of West Sacramento provided utility mapping that detailed the pipe sizes and locations for water, sewer and gas.

## 2.8 CONSTRUCTION ACCESS, HAUL ROUTES, AND STAGING AREAS

Permanent access along most of the project is currently available using existing levee access roads. For scour protection, sites along the Sacramento River are anticipated to be constructed using barges. Additional waterside access roads will be constructed for the bank protection sites for the Sacramento River levees.

For other site features, the permanent easements associated with this project are expected to be adequate for construction of the features. Further refinement of access requirements will be analyzed during the Preconstruction, Engineering and Design (PED) phase.

Haul routes will generally use existing public roadways that connect to the existing project. As borrow sources were not specifically identified, exact haul routes were not identified.

There are available sites such as farm land, parks, levee ramps, and vacant land available along the levees that may serve as staging areas. The exact need for staging areas and identification of areas will be completed during the PED phase.

## 2.9 REAL ESTATE REQUIREMENTS

Real estate requirements for the project area consisted of Permanent Flowage Easements (PFE), Flood Protection Levee Easements (FPLE), Bank Protection Easement (BPE), and vegetation free easements. These easements were needed to provide adequate construction room to build proposed flood mitigation features, secure lands needed for Operations and Maintenance (O&M), and acquire lands needed to comply with Corps vegetation policies. The easements are described in Sacramento District Standard Operating Procedures (SOP), and summarized below as they apply to the project.

- Bank Protection – Easement needed for construction and maintenance of erosion protection features. Included are the rights to trim and cut vegetation, shape and grade slope, and replace riprap. The easement includes all area required to construct and maintain erosion protection features that are outside of the FPLE.
- Waterside 15 ft – Easement needed for O&M from the waterside toe and to restrict woody vegetation growth per Engineering Technical Letter (ETL) 1110-2-571. This easement includes the entire area from the waterside toe to an offset line 15 feet towards the river.

The levees will have a permanent FPLE, which will provide space for the levee, landside seepage remediation, and a 20-foot operations and maintenance right-of-ways on the landside of the seepage remediation feature and waterside toe. Easements are necessary for maintenance, inspection, and flood fight access.

- Flood Protection Levee Easement – Needed for levee setback areas and in locations where the local maintaining agency does not have sufficient rights on the levee. These include the right to

construct, maintain, repair, operate and patrol the flood protection features. This easement includes all area from landside toe to waterside toe of the existing and/or proposed levee. Refinement of these footprints will be provided in final design prior to levee construction.

More information on the types of easements, relocations, and estimates can be found in the Real Estate Appendix.

## **2.10 OPERATION AND MAINTENANCE**

The Non-Federal Sponsor is responsible for project Operation, Maintenance Repair, Replacement and Rehabilitation (OMRR&R) for project features. The West Sacramento GRR adds features to the existing flood protection system. Generally, the local sponsor will have to increase mowing, rodent control, and encroachments removal for the proposed levee improvements. The required maintenance for the floodwalls includes caulking and graffiti removal. For the closure structure proposed on the Deep Water Ship Channel the OMRR&R will include operation of the gate, dive team inspections, and dewatering.

For the selected plan, the project features will be determined whether they add any additional O&M responsibility for the Non-Federal Sponsor. If there are increased OMRR&R efforts for the project features, an appropriate cost will be quantified to reflect the addition effort as part of the final report.

## **3 - PROJECT DESIGN FEATURES AND ALTERNATIVES**

### **3.1 ALTERNATIVES**

A wide range of features were evaluated to reduce flood risk in the project area. For the purposes of this study, the alternatives were developed by combining measures. Below is the preliminary array of alternatives that were considered:

- Alternative 1 – Improve levees
- Alternative 2 – Improve levees and Sacramento Bypass widening
- Alternative 3 – Improve levees and DWSC Closure Structure
- Alternative 4 – Improve levees, Sacramento Bypass widening and DWSC closure structure
- Alternative 5 – Improve levees and Sacramento River South Setback Levee

The project development team further refined the array of alternatives by screening out the Sacramento Bypass widening measure. The final array of alternatives only includes alternatives 1, 3 and 5. The civil design for the project only considers the final array of alternatives.

#### **3.1.1 Alternative 1 – Improve Levees**

Alternative 1 involves the construction of levee remediation measures to address deficiencies such as seepage, slope instability, height, and erosion along the Sacramento River, the Sacramento Bypass, Yolo Bypass and the Sacramento DWSC. This alternative combines construction of improvement measures while maintaining the present levee alignment in its existing location (fix in place). A summary of the proposed improvement by reach is in Table 2.

**Table 2: Alternative 1 – Proposed Features**

ALTERNATIVE 1 – IMPROVE LEVEES					
REACH	REACH LENGTH FEET	FEATURE LENGTH FEET	IMPROVEMENT	FIGURE NUMBER	FEATURES
Sacramento Bypass	6,478	-	None	-	None
Yolo Bypass	19,749	3,860	Landside Slope	6	Flatten Landside Slope
		2,500	Seepage, Stability	5	Flatten Landside Slope/ 40' Slurry wall
		1,900	Seepage	4	100' Slurry Wall
DWSC West Levee	100,260	9,000	Height/Seepage	4	85' Slurry Wall
		7,000	Height/Seepage	4	50' Slurry Wall
		9,000	Height/Seepage	4	75' Slurry Wall
		75,260	Height	3	Embankment Fill
		99,010	Erosion	-	Bank Protection (120'x3' depth)
DWSC East Levee	17,171	1,500	Seepage	4	120' Slurry Wall, DSM
		7,055	Seepage	4	130' Slurry Wall, DSM
		5,945	Seepage	4	50' Slurry Wall
		2,671	Height	3	Embankment Fill
Port North	23,225	8,245	Height	2	Floodwall, 4' to 10'
		14,170	Height	3	Embankment Fill
Port South	16,262	15,560	Height	3	Embankment Fill
		1,000	Seepage	4	70' Slurry Wall
South Cross Levee	6,273	1,100	Stability, Height	7	Stability Berm and Embankment Fill
		5,000	Seepage, Height	8	Relief Wells and Embankment Fill
Sacramento River North Levee	30,700	30,000	Erosion	11	Bank Protection
		11,080	Seepage	4	30' Slurry Wall
		1,470	Seepage	4	80' Slurry Wall
		500	Seepage	4	45' Slurry Wall
		5,530	Seepage	4	110' Slurry Wall
		4,600	Height	3	Embankment Fill
Sacramento River South Levee	33,100	33,100	Seepage, Height, Erosion	13	Slurry wall, 80' Berm, Bank protection
Stone Lock	570	540	Flow Direction	9	Embankment Fill, Sheet Pile Wall
Sacramento Bypass Training Dike	3,000	3,000	Erosion	10	Bank Protection

### 3.1.2 Alternative 3 – Improve Levees and DWSC Closure Structure

Alternative 3 applies many of the levee remediation measures proposed in Alternative 1 (Improve Levees) and adds a closure structure along the DWSC. The closure structure eliminates the need for levee improvements along Port North and Port South. It also reduces the length of improvements from the DWSC West and DWSC East levees. A summary of the proposed improvements is in Table 3.

### 3.1.2.1 *Deep Water Ship Channel Closure Structure*

The DWSC closure structure (figure 12) will be a sector gated structure with a two hundred (200) foot wide opening and a sill elevation of -37.0 and top of structure elevation of + 34.0, constructed in the DWSC approximately five hundred (500) feet north of the South Basin Main Drain Pumping Plant. Tie-in levees are provided on either side of the structure to tie into the existing levees along the channel.

The structure consists of conventionally reinforced concrete and post tensioned concrete supported on a pipe pile foundation. The concrete structure will use float-in construction. The concrete shell will be built similar to barge type construction and designed using naval architecture methods for transportation and installation conditions. A graving site will be provided adjacent to the project site for construction of the reinforced concrete sector gate monolith. The float-in design eliminates the need for cofferdams, structure site dewatering systems, and structure site bypass.

The conceptual level design for the DWSC closure structure was developed by the New Orleans District (MVN).

**Table 3: Alternative 3 – Proposed Features**

ALTERNATIVE 3 – IMPROVE LEVEES AND DWSC CLOSURE STRUCTURE					
REACH	REACH LENGTH FEET	FEATURE LENGTH FEET	IMPROVEMENT	FIGURE NUMBER	FEATURES
Sacramento Bypass	6,478	-	None	-	None
Yolo Bypass	19,749	3,860	Landside Slope	6	Flatten Landside Slope
		2,500	Seepage, Stability	5	Flatten Landside Slope/ 40' Slurry wall
		1,900	Seepage	4	100' Slurry Wall
DWSC West Levee with Closure Structure	12,300	9,000	Seepage	4	85' Slurry Wall
		11,160	Height	3	Embankment Fill
		11,050	Erosion	-	Bank Protection
DWSC East Levee with Closure Structure	5,671	5,671	Seepage, Height	4	50' Slurry Wall
South Cross Levee	6,273	1,100	Stability, Height	7	Stability Berm and Embankment Fill
		5,000	Seepage ,Height	8	Relief Wells and Embankment Fill
Sacramento River North Levee	30,700	30,000	Erosion	11	Bank Protection
		11,080	Seepage	4	30' Slurry Wall
		1,470	Seepage	4	80' Slurry Wall
		500	Seepage	4	45' Slurry Wall
		5,530	Seepage	4	110' Slurry Wall
		4,600	Height	3	Embankment Fill
Sacramento River South Levee	33,100	33,100	Seepage, Height, Erosion	13	Slurry wall, 80' Berm, Bank protection
Stone Lock	570	540	Flow Direction	9	Embankment Fill, Sheet Pile Wall
Sacramento Bypass Training Dike	3,000	3,000	Erosion	10	Bank Protection
Closure Structure on DWSC	-	-	-	12	Closure Structure

Note: Deep Water Ship Channel (DWSC) includes Closure Structure (See Figure 12).

### 3.1.3 Alternative 5 – Improve Levees and Sacramento River South Setback Levee

Alternative 5 applies many of the levee remediation measures proposed in Alternative 1 (Improve Levees) except along the Sacramento River South levee reach. The Sacramento River South levee alignment includes fix-in-place, adjacent and a setback levee. This alignment is the same alignment that is being considered in the Non-Federal Sponsors Southport early implementation project (EIP). A summary of the proposed improvements is in Table 4.

**Table 4: Alternative 5 – Proposed Features**

Alternative 5 – Improve Levees and Sacramento River South Setback					
Reach	Reach Length Feet	Feature Length Feet	Improvement	Figure Number	Features
Sacramento Bypass	6,478	-	None	-	None
Yolo Bypass	19,749	3,860	Landside Slope	6	Flatten Landside Slope
		2,500	Seepage, Stability	5	Flatten Landside Slope/ 40' Slurry wall
		1,900	Seepage	4	100' Slurry Wall
DWSC West Levee	100,260	9,000	Seepage, Height	4	85' Slurry Wall
		7,000	Seepage, Height	4	50' Slurry Wall
		9,000	Seepage, Height	4	75' Slurry Wall
		75,260	Height	3	Embankment Fill
		99,010	Erosion	-	Bank Protection (120' x3' Depth)
DWSC East Levee	17,171	1,500	Seepage	4	120' Slurry Wall, DSM
		7,055	Seepage	4	130' Slurry Wall, DSM
		5,945	Seepage	4	50' Slurry Wall
		2,671	Height	3	Embankment Fill
Port North	23,225	8,245	Height	2	Floodwall, 4' to 10'
		14,170	Height	3	Embankment Fill
Port South	16,262	15,560	Height	3	Embankment Fill
		1,000	Seepage	4	70' Slurry Wall
South Cross Levee	6,273	1,100	Stability, Height	7	Stability Berm and Embankment Fill
		5,000	Seepage, Height	8	Relief Wells and Embankment Fill
Sacramento River North Levee	30,700	30000	Erosion	11	Bank Protection
		11,080	Seepage	4	30' Slurry Wall
		1,470	Seepage	4	80' Slurry Wall
		500	Seepage	4	45' Slurry Wall
		5,530	Seepage	4	110' Slurry Wall
		4,600	Height	3	Embankment Fill
Sacramento River South Levee (Setback Levee)	29,320	6,578	Erosion	14-16	Bank Protection
		29,320	Seepage, Height	14-21	Embankment Fill and Slurry Wall/Berm
Stone Lock	570	540	Flow Direction	9	Embankment Fill, Sheet Pile Wall
Sacramento Bypass Training Dike	3,000	3,000	Erosion	10	Bank Protection

### 3.2 CONSTRUCTION DURATION

For each of the alternatives, the minimum years to construct each reach was developed using the construction quantities and the production rates for the construction crews. The levee prioritization was developed based on economic data and input from the Non-Federal Sponsors. The actual construction duration for the reaches will depend on the available funding and environmental emissions constraints. The minimum years to construct for each alternative are summarized in Tables 5 - 7.

**Table 5: Alternative 1 – Minimum Years to Construct**

ALTERNATIVE 1 – MINIMUM YEARS TO CONSTRUCT					
REACH	REACH LENGTH FEET	FEATURE LENGTH FEET	IMPROVEMENT	YEARS TO CONSTRUCT	NOTES
Sacramento Bypass	6,478	-	None		No Repair
Yolo Bypass	19,749	3,860	Landside Slope	1	
		2,500	Seepage, Stability		
		1,900	Seepage		
DWSC West Levee	100,260	9,000	Height/Seepage	3	Requires 3 rock import crews
		7,000	Height/Seepage		
		9,000	Height/Seepage		
		75,260	Height		
		99,010	Erosion		
DWSC East Levee	17,171	1,500	Seepage	3	Requires 2 DSM crews
		7,055	Seepage		
		5,945	Seepage		
		2,671	Height		
Port North	23,225	8,245	Height	2	
		14,170	Height		
Port South	16,262	15,560	Height	1	
		1,000	Seepage		
South Cross Levee	6,273	1,100	Stability, Height	2	Requires 2 import crews
		5,000	Seepage, Height		
Sacramento River North Levee	30,700	30,000	Erosion	2	Requires 2 DSM crews, and 3 rock crews
		11,080	Seepage		
		1,470	Seepage		
		500	Seepage		
		5,530	Seepage		
Sacramento River South Levee	33,100	33,100	Seepage, Height, Erosion	4	Requires 2 export crews, 2 rock crews, and 3 import crews
Sacramento Bypass Training Dike	3,000	3,000	Erosion	1	

**Table 6: Alternative 3 – Minimum Years to Construct**

ALTERNATIVE 3 – MINIMUM YEARS TO CONSTRUCT					
REACH	REACH LENGTH FEET	FEATURE LENGTH FEET	IMPROVEMENT	YEARS TO CONSTRUCT	NOTES
Sacramento Bypass	6,478	-	None		No Repair
Yolo Bypass	19,749	3,860	Landside Slope	1	
		2,500	Seepage, Stability		
		1,900	Seepage		
DWSC West Levee with Closure Structure	12,300	9,000	Seepage	2	
		11,160	Height		
		11,050	Erosion		
DWSC East Levee with Closure Structure	5,671	5,671	Seepage, Height	1	Requires 2 import crews
South Cross Levee	6,273	1,100	Stability, Height	2	
		5,000	Seepage, Height		
Sacramento River North Levee	30,700	30,000	Erosion	2	Requires 2 DSM crews, and 3 rock crews
		11,080	Seepage		
		1,470	Seepage		
		500	Seepage		
		5,530	Seepage		
		4,600	Height		
Sacramento River South Levee	33,100	33,100	Seepage, Height, Erosion	4	Requires 2 export crews, 2 rock crews, and 3 import crews
Sacramento Bypass Training Dike	3,000	3,000	Erosion	1	
Closure Structure	-	-	-	3.5	

**Table 7: Alternative 5 – Minimum Years to Construct**

Alternative 5 – Minimum Years to Construct					
Reach	Reach Length Feet	Feature Length Feet	Improvement	Years to Construct	Notes
Sacramento Bypass	6,478	-	None		No Repair
Yolo Bypass	19,749	3,860	Landside Slope	1	
		2,500	Seepage, Stability		
		1,900	Seepage		
DWSC West Levee	100,260	9,000	Height/Seepage	3	Requires 3 rock import crews
		7,000	Height/Seepage		
		9,000	Height/Seepage		
		75,260	Height		
		99,010	Erosion		
DWSC East Levee	17,171	1,500	Seepage	3	Requires 2 DSM crews
		7,055	Seepage		
		5,945	Seepage		
		2,671	Height		
Port North	23,225	8,245	Height	2	
		14,170	Height		
Port South	16,262	15,560	Height	1	
		1,000	Seepage		
South Cross Levee	6,273	1,100	Stability, Height	2	Requires 2 import crews
		5,000	Seepage, Height		
Sacramento River North Levee	30,700	30,000	Erosion	2	Requires 2 DSM crews, and 3 rock crews
		11,080	Seepage		
		1,470	Seepage		
		500	Seepage		
		5,530	Seepage		
		4,600	Height		
Sacramento River South Levee (Setback Levee)	29,320	6,578	Erosion	4	
		29,320	Seepage, Height		
Sacramento Bypass Training Dike	3,000	3,000	Erosion	1	

### 3.3 CIVIL ESTIMATES

Quantities were arrived at by producing templates corresponding to the recommendations Soils Design provided. InRoads, a product of Bentley, produced material summaries that were summarized by reach and displayed within Excel spreadsheets. Utilities came from a variety of sources, including HDR Utility Summary for West Sacramento, City of West Sacramento (water, storm sewer, and sanitary sewer maps), GIS data from our Levee Safety Section, Google Earth (obstructions, trees, utilities poles, and homes), and Department of Water Resources Levee Logs. Utilities were summarized by reach on a single Excel Spreadsheet. The Setback Levee, Alternative 5, is currently under final design and the quantities were taken directly from the designers.

### **3.4 RELOCATIONS**

Relocation of power poles within each of the alternatives was determined by inspection of the footprints. Buildings falling within the footprints were demolished or moved based upon the easement requirements. If the levee profile height increased, then it was assumed that the discharge pumps and piping would be replaced for each occasion. The utility summary for each reach was made available to the estimator and can be reviewed upon request. It shows the type of fix required whether jet grouting or replacement occurs.

## **ATTACHMENT 1 - FIGURES**

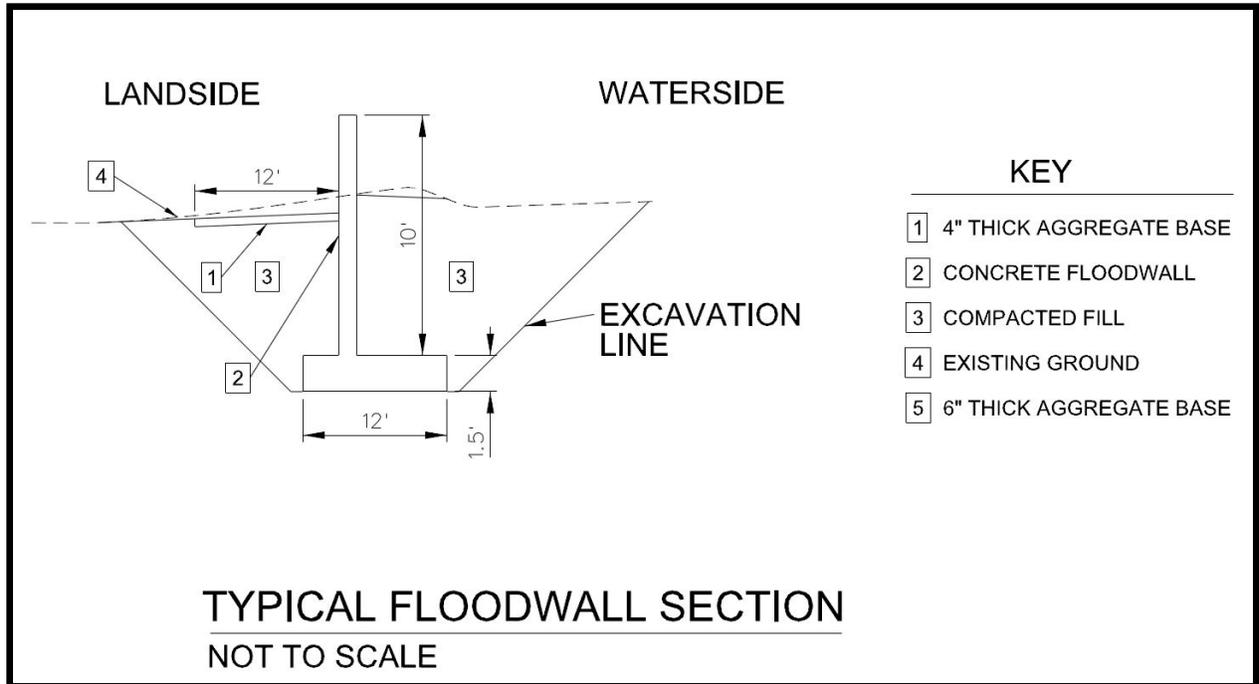

Figure 2: Typical Floodwall Section

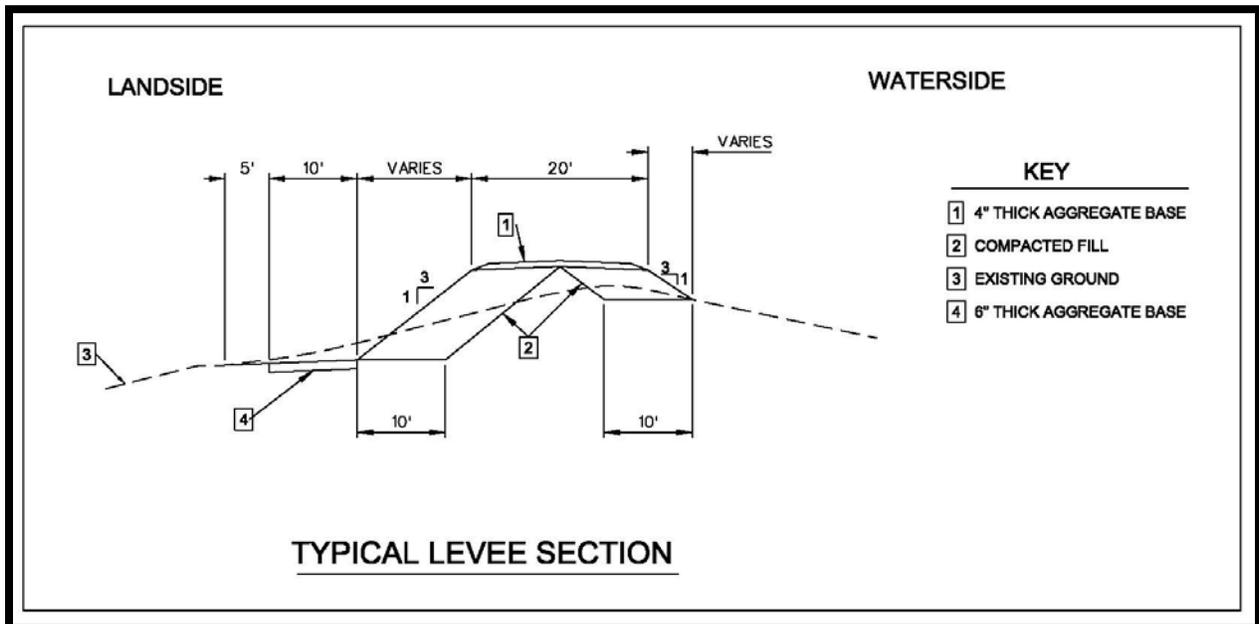

Figure 3: Typical Levee Section

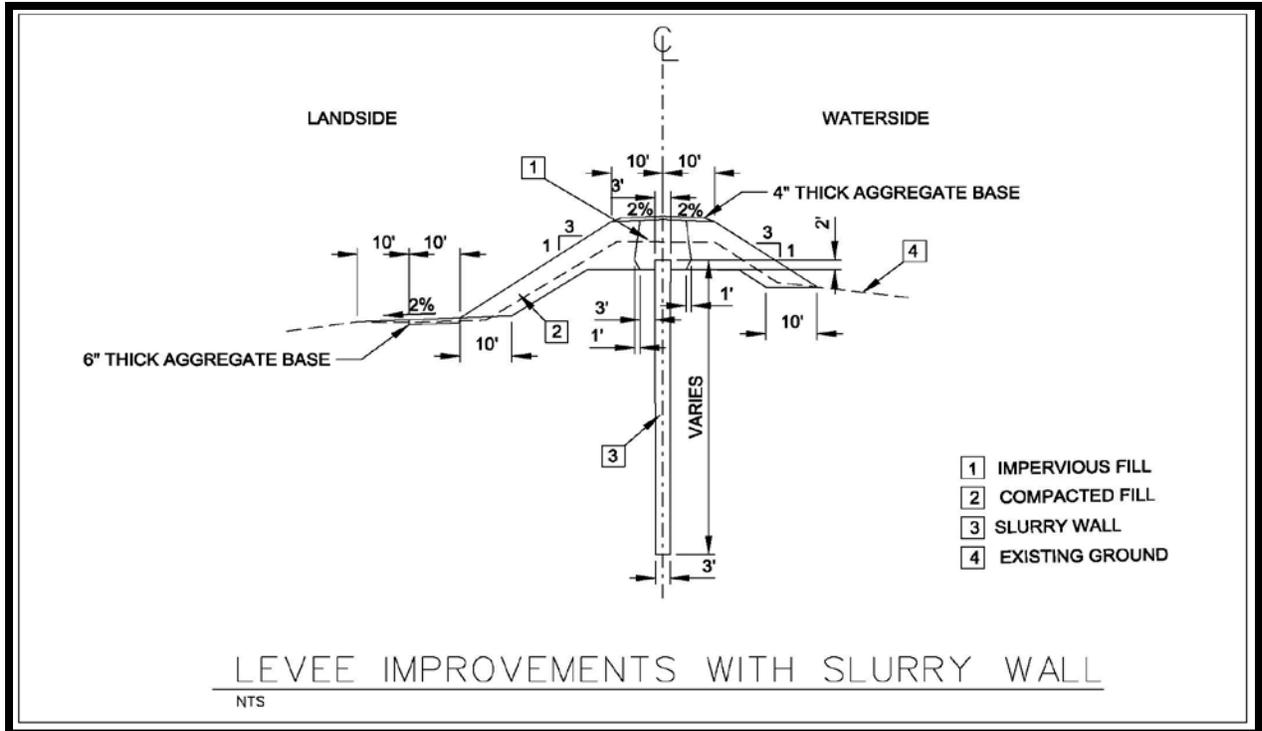

Figure 4: Levee Improvements with Slurry Wall

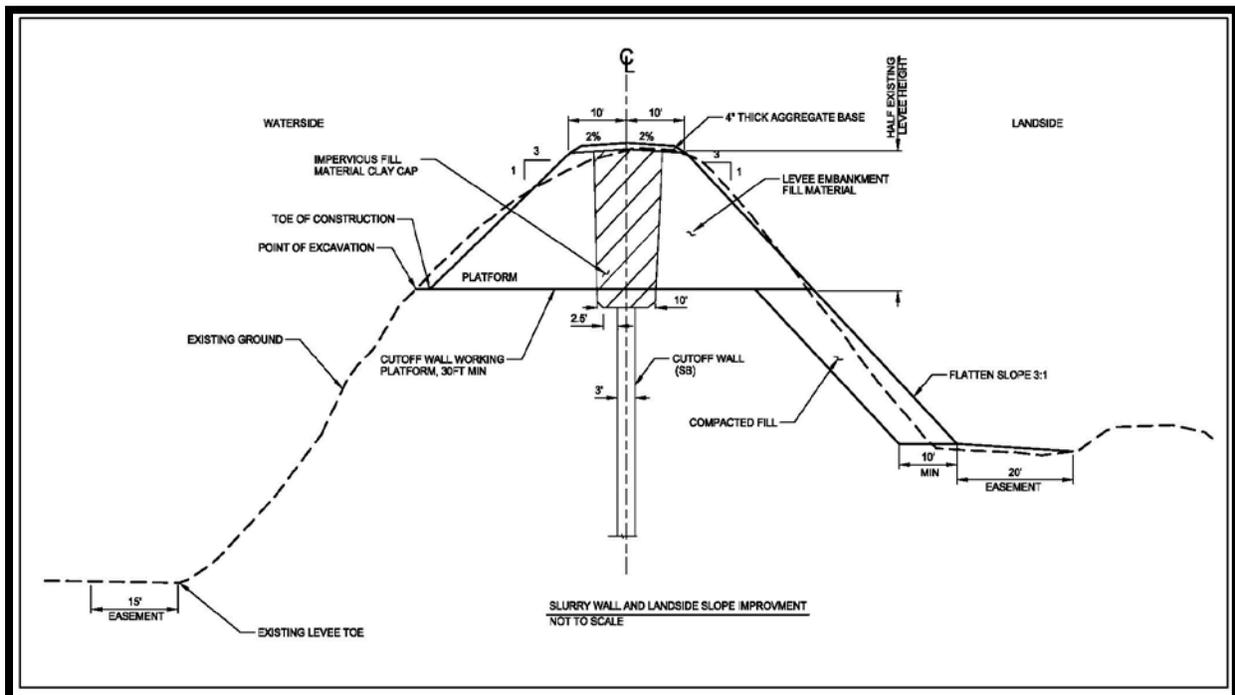

Figure 5: Slurry Wall and Landside Slope Improvement

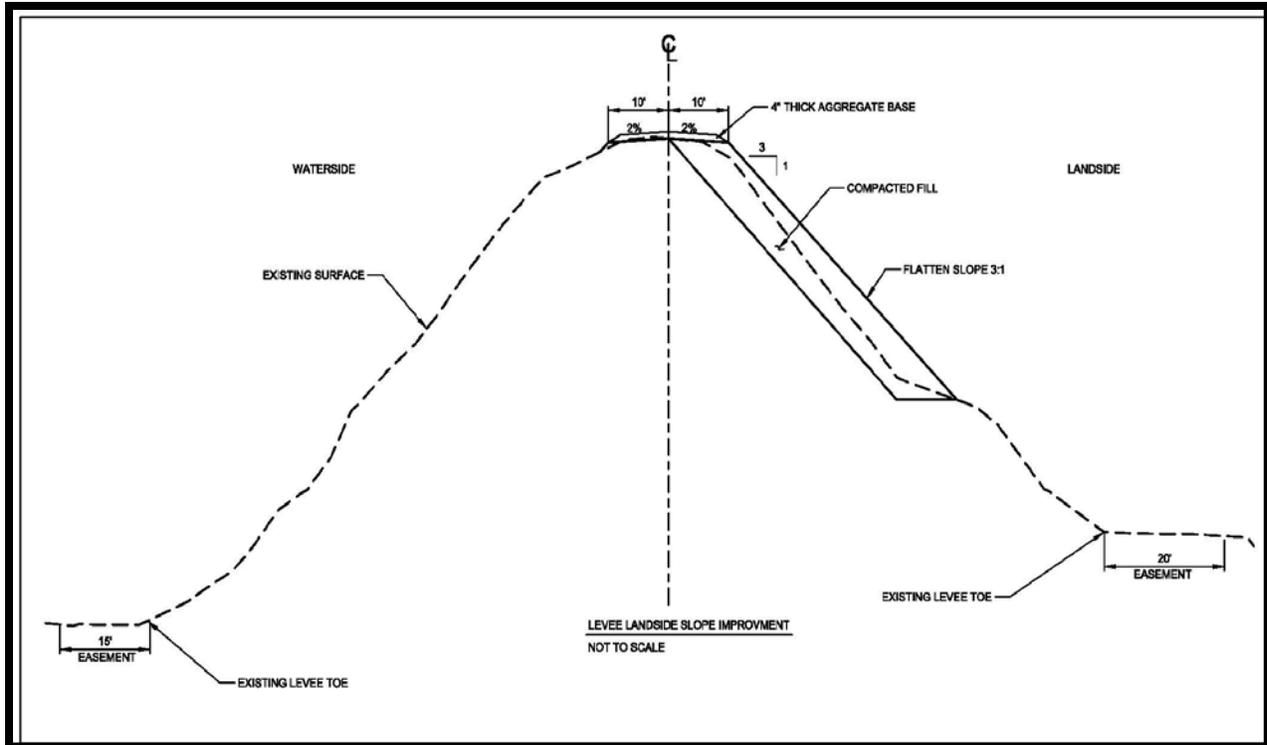

Figure 6: Levee Landside Slope Improvement

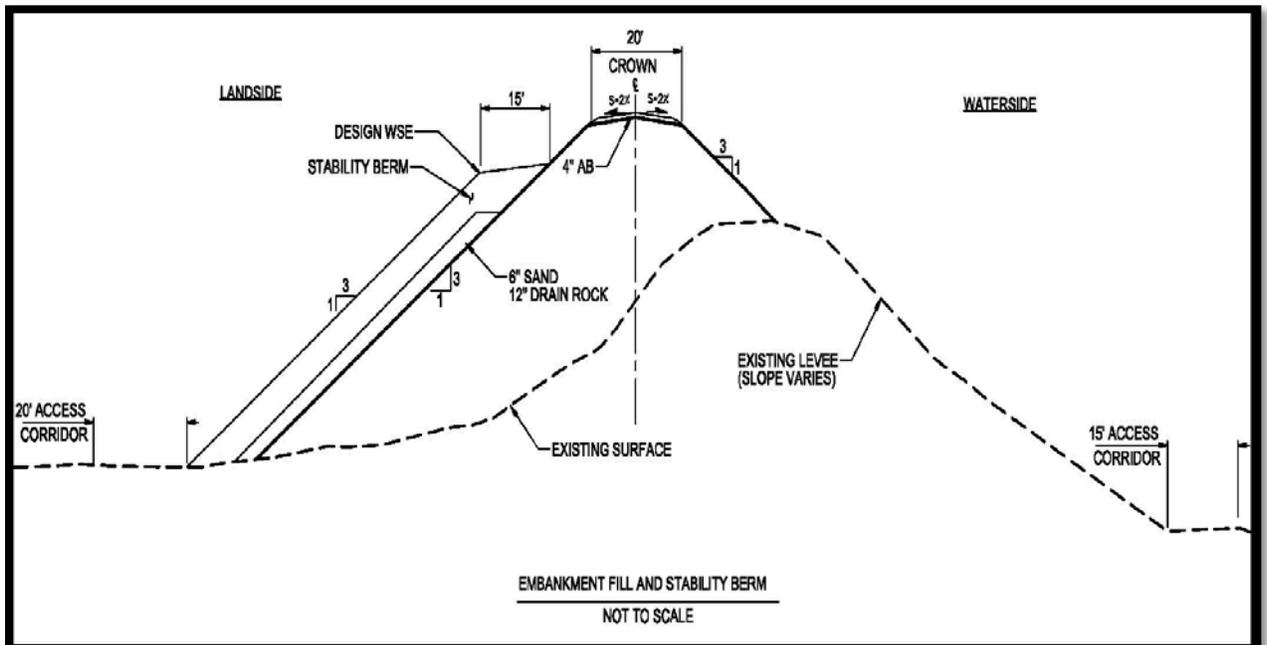

Figure 7: Embankment Fill and Stability Berm

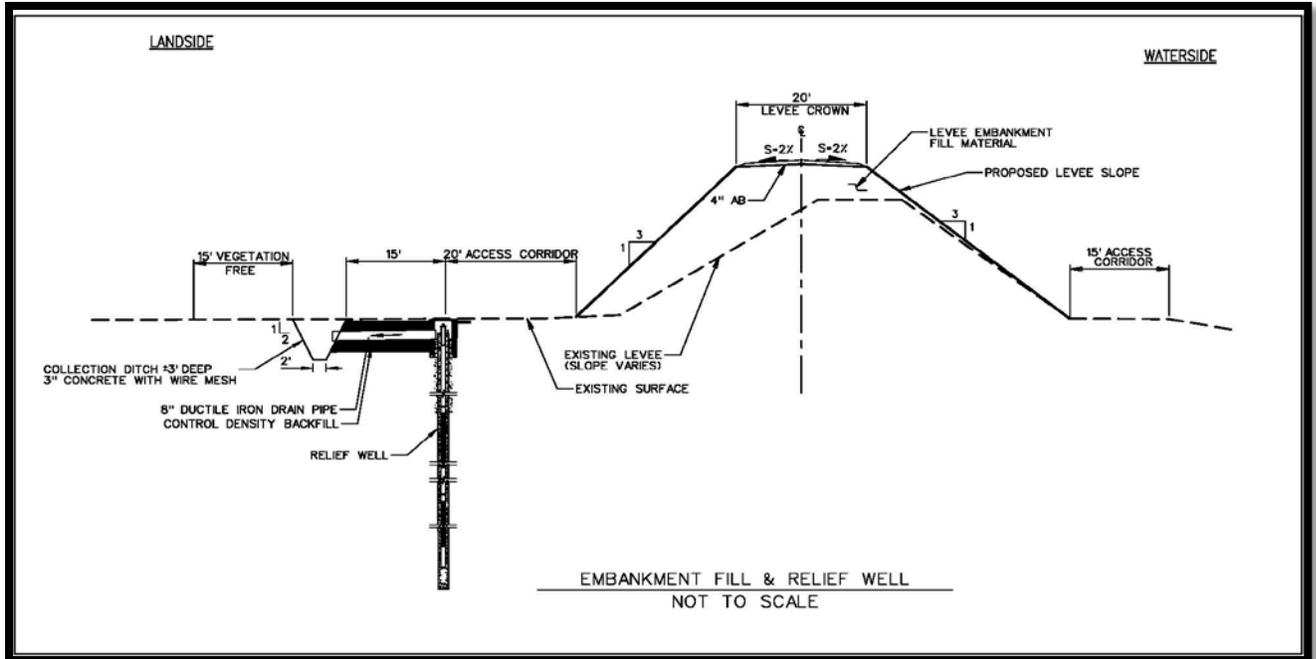

Figure 8: Embankment Fill & Relief Well

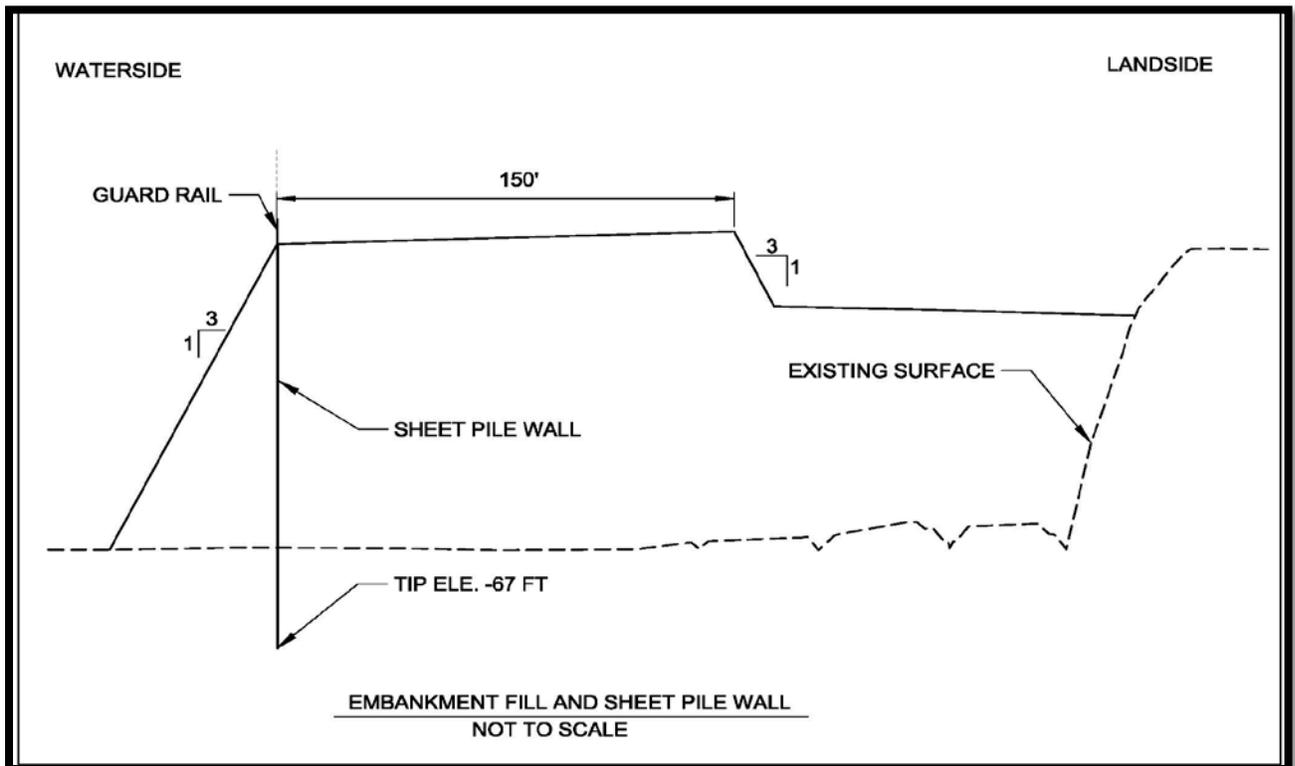

Figure 9: Embankment Fill and Sheet Pile Wall

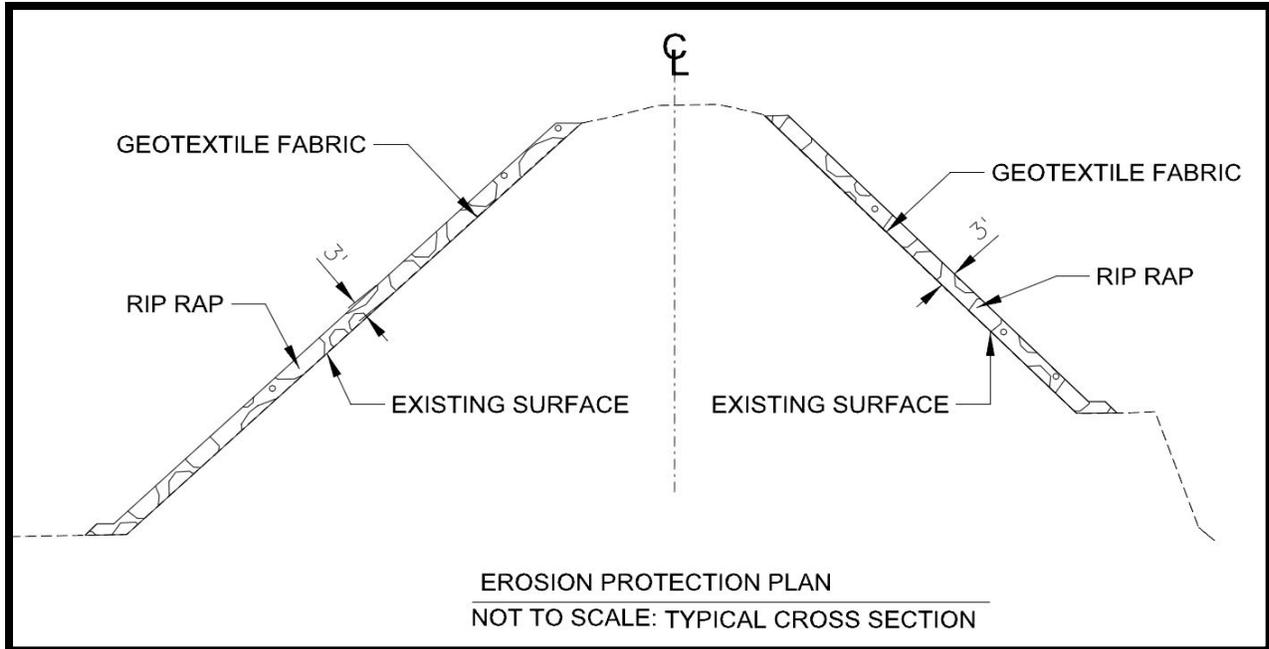

Figure 10: Erosion Protection Plan

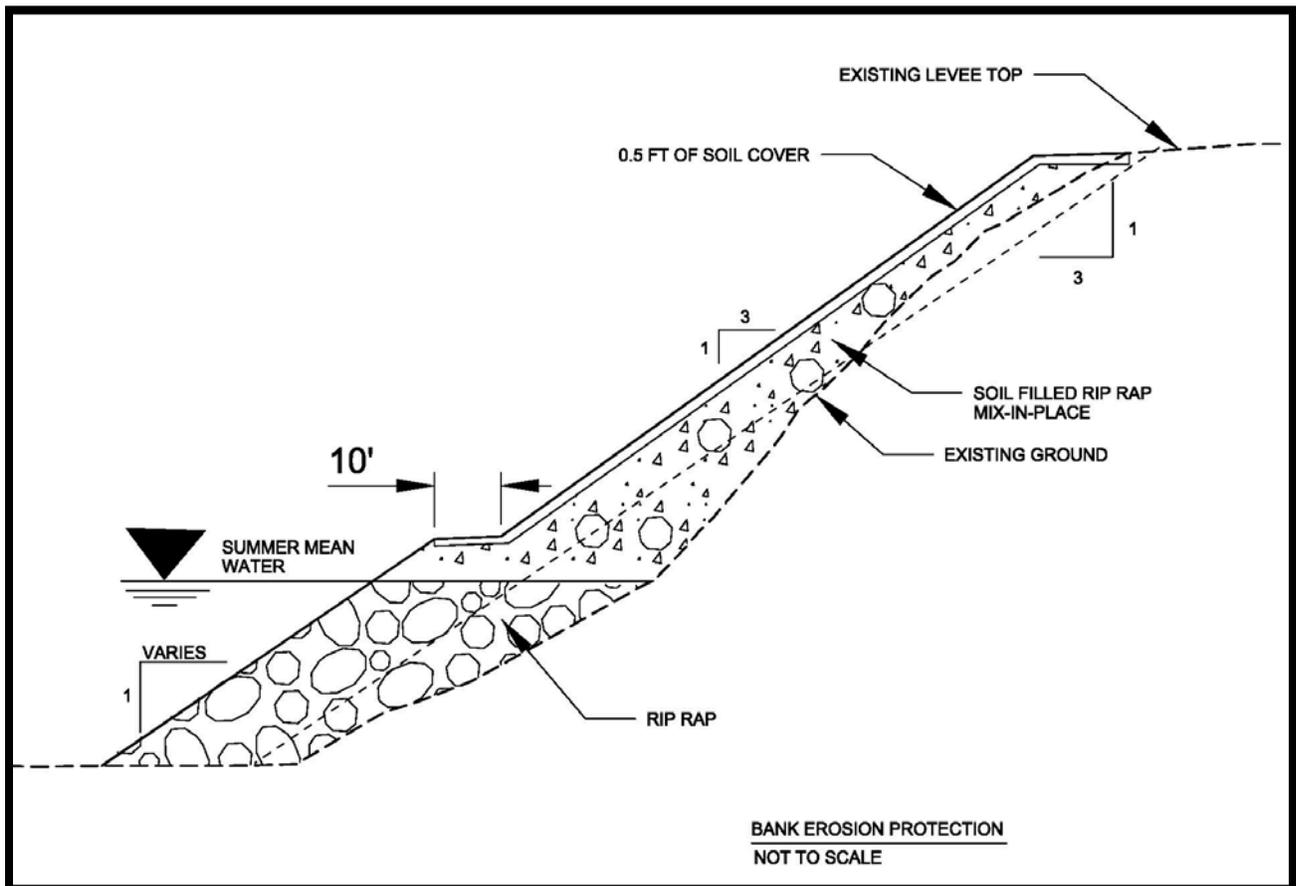

Figure 11: Bank Erosion Protection

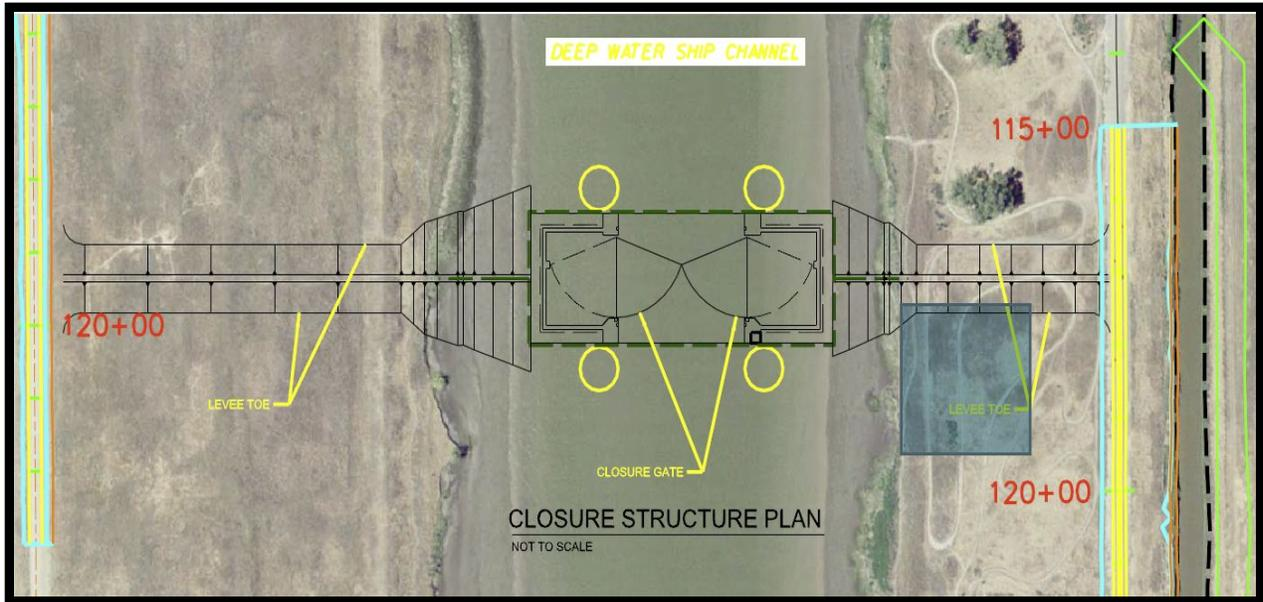

Figure 12: DWSC Closure Structure Plan

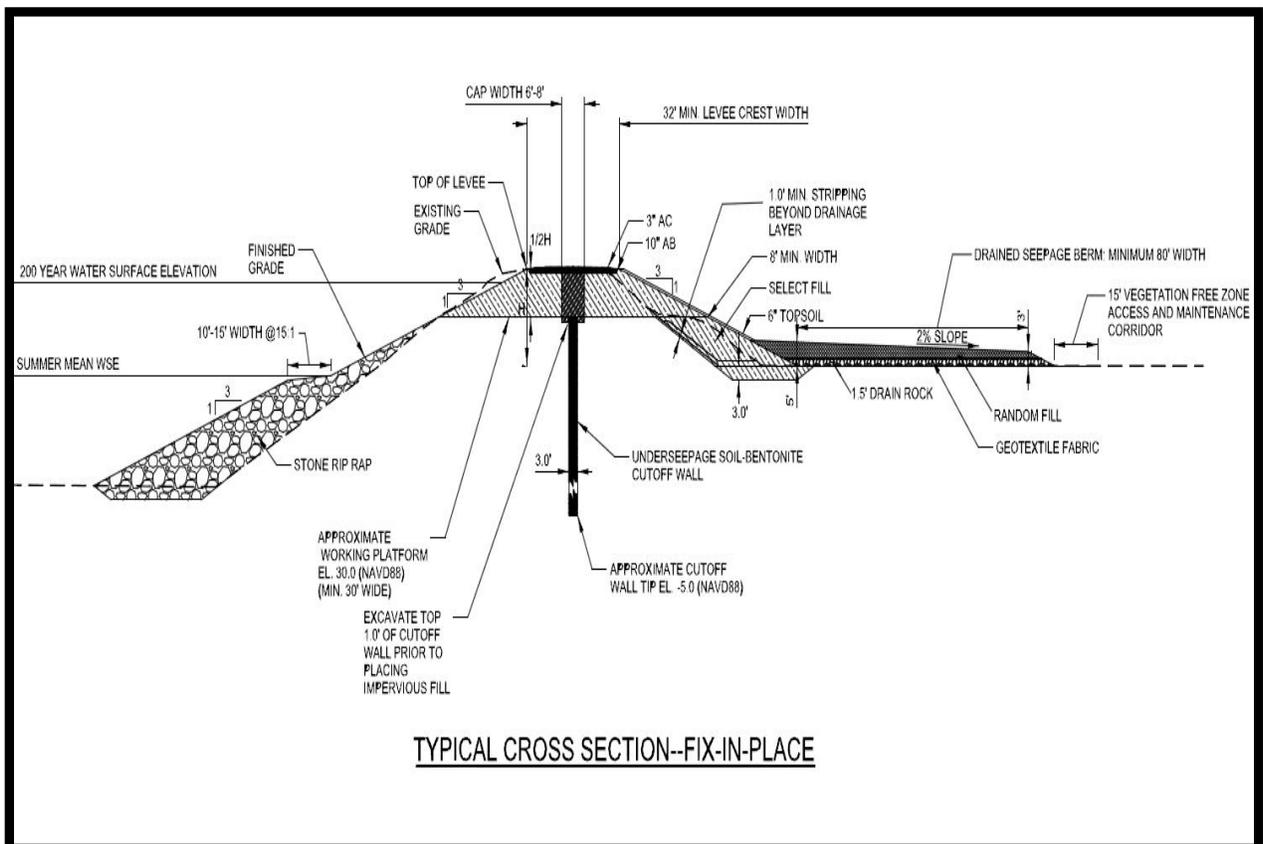

Figure 13: Typical Cross Section Fix-in-Place

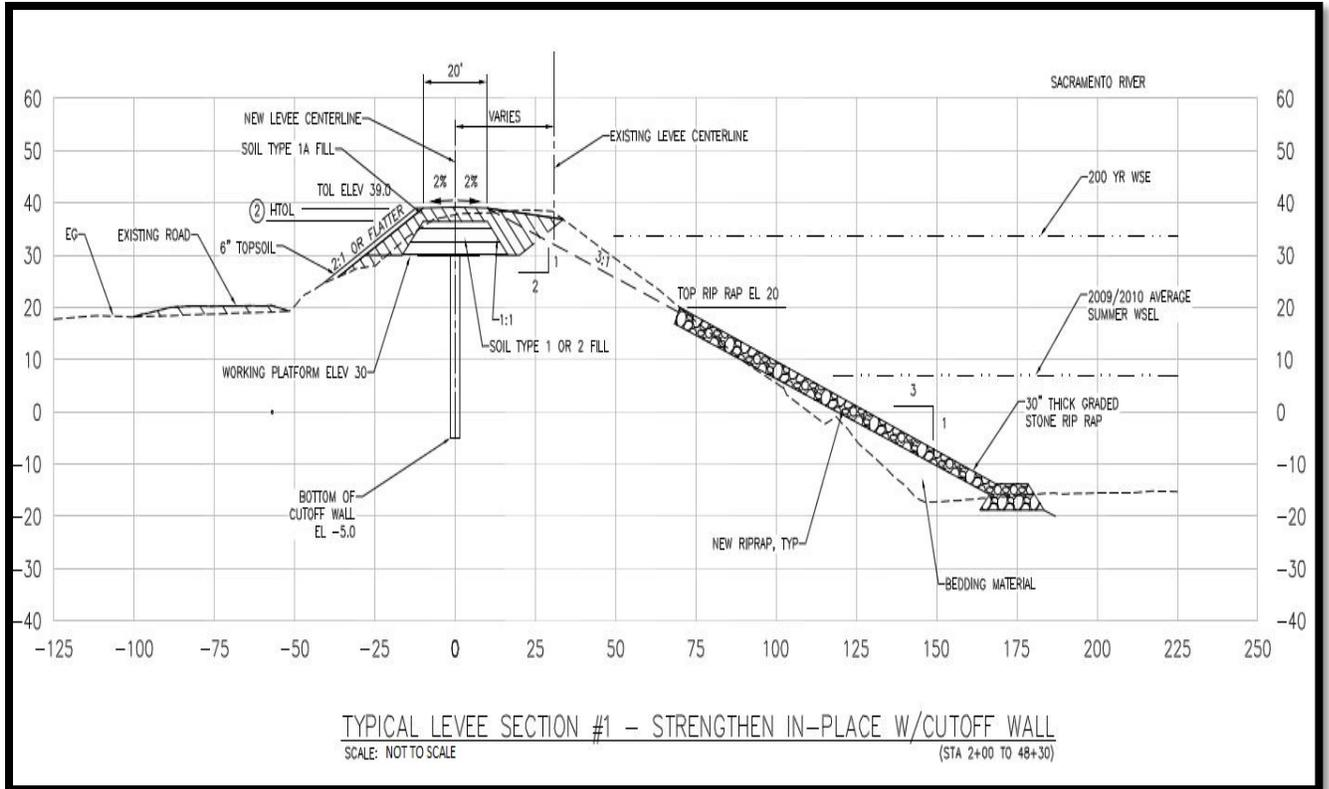

Figure 14: Typical Cross Section Strengthen In-Place with Cutoff wall

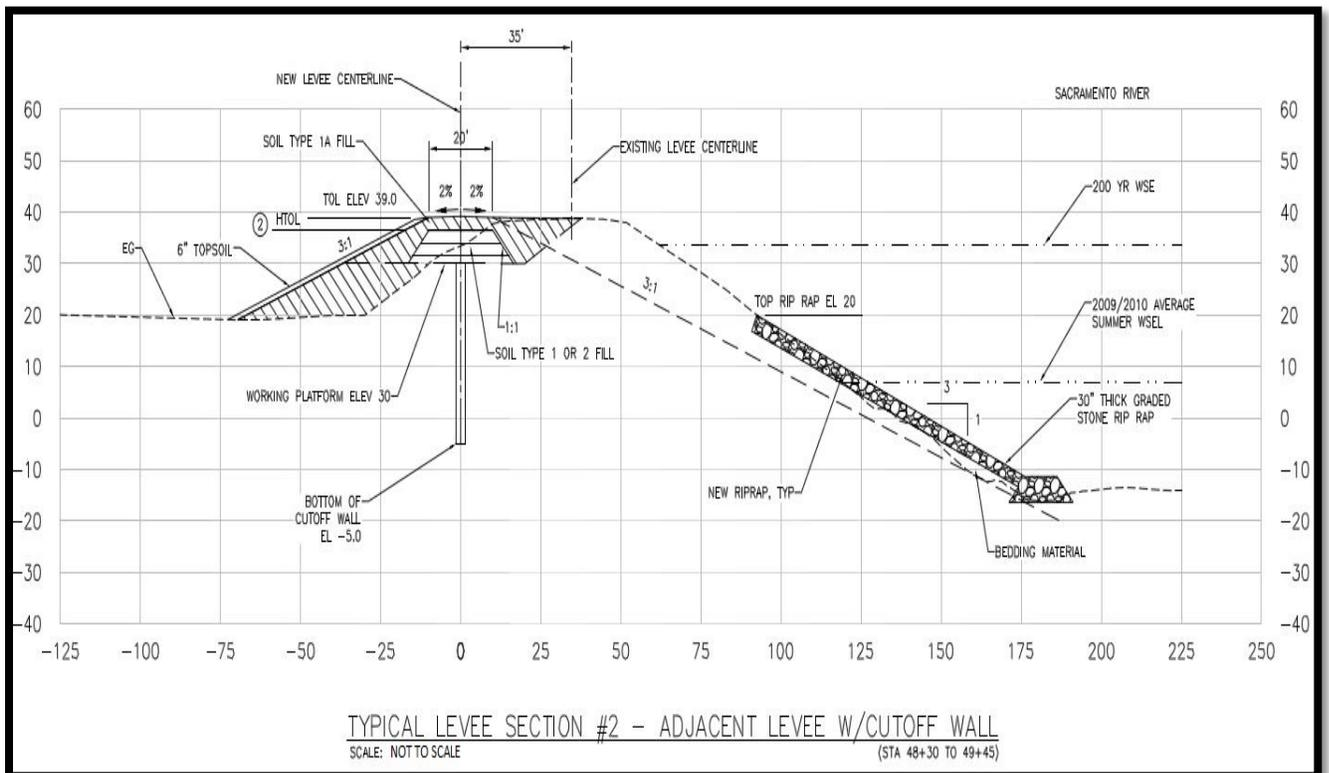

Figure 15: Typical Cross Section - Adjacent Levee with Cutoff Wall

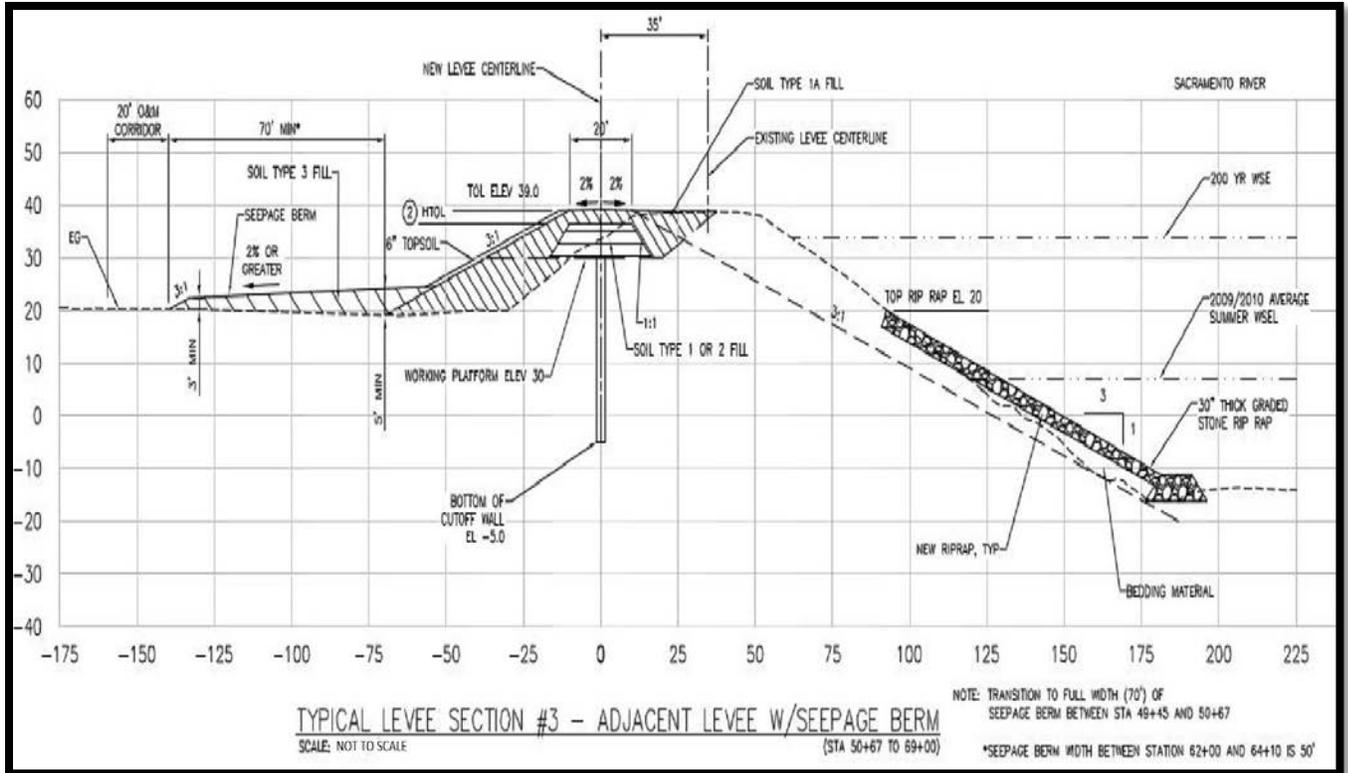

Figure 16: Adjacent Levee with Seepage Berm

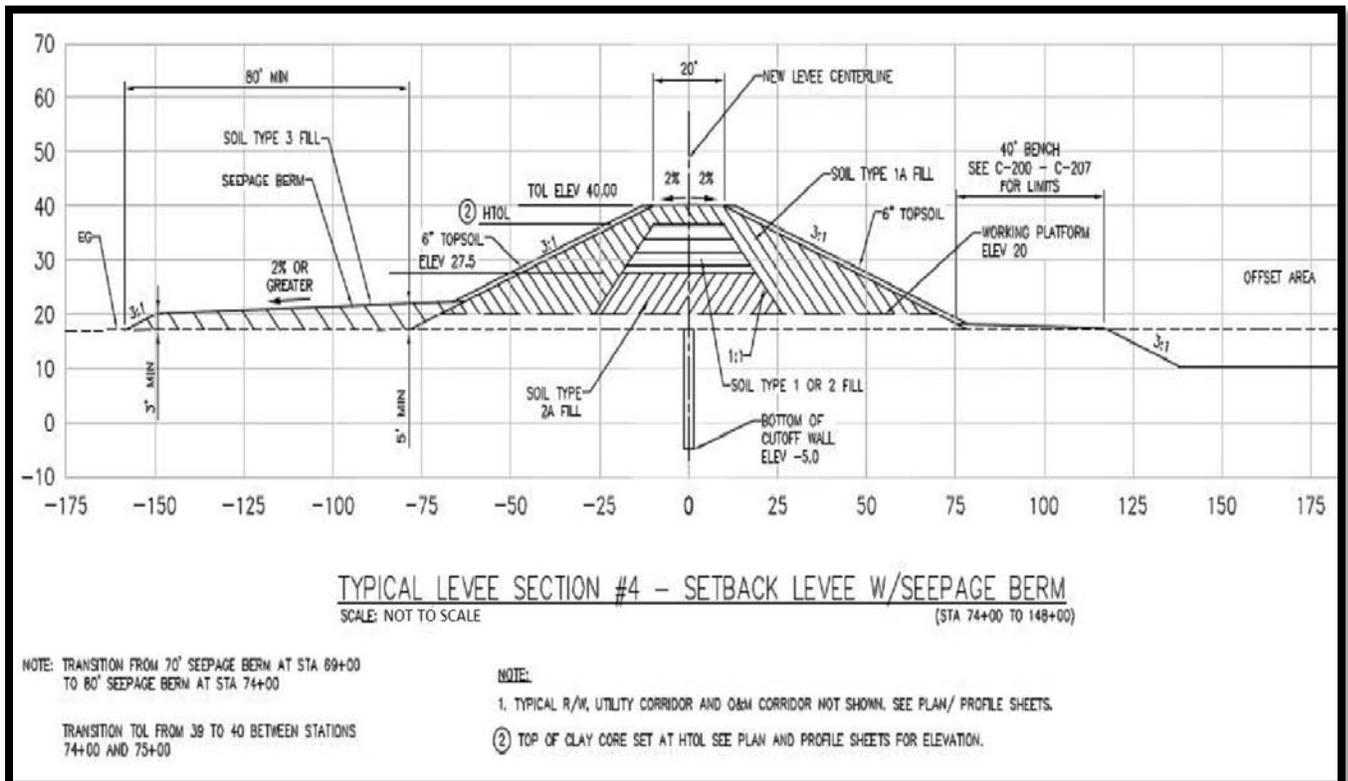

Figure 17: Setback Levee with Seepage Berm

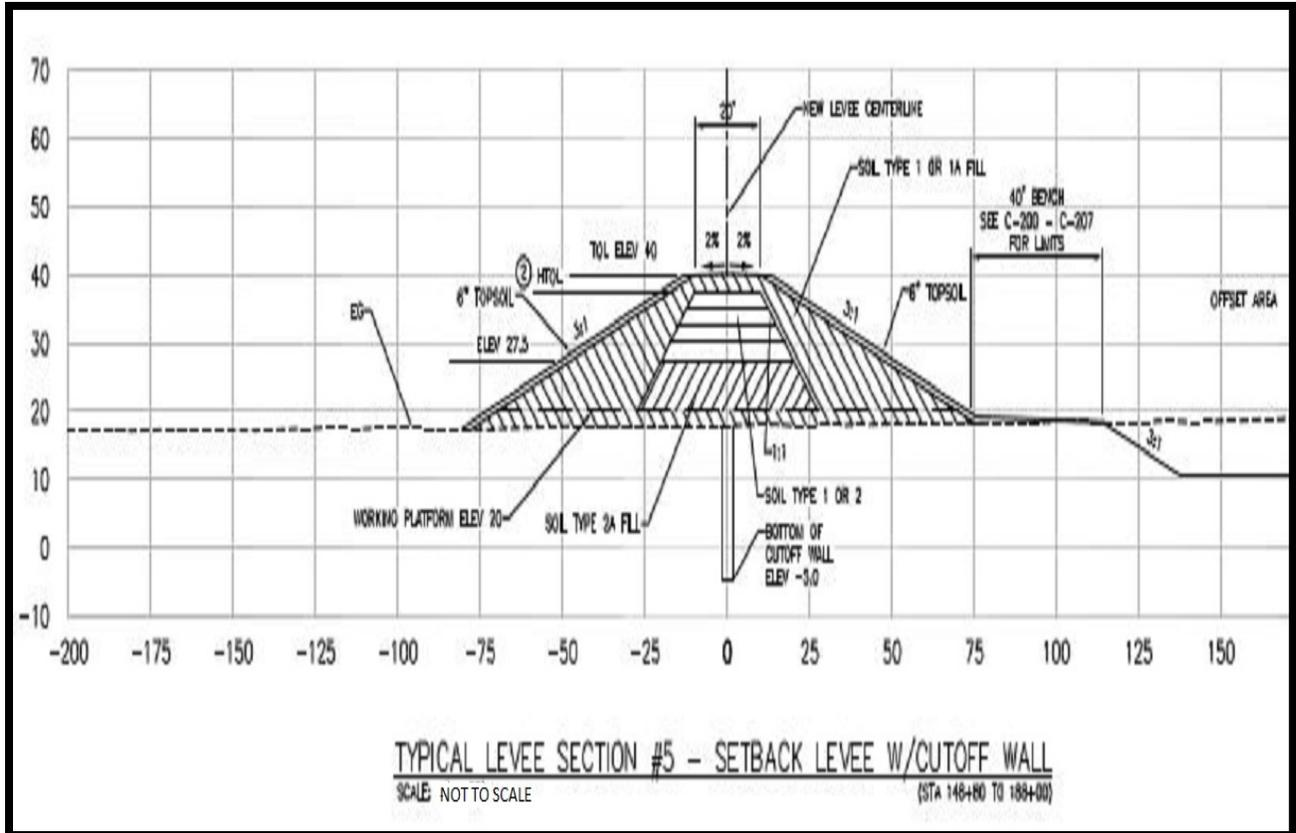

Figure 18: Setback Levee with Cutoff Wall

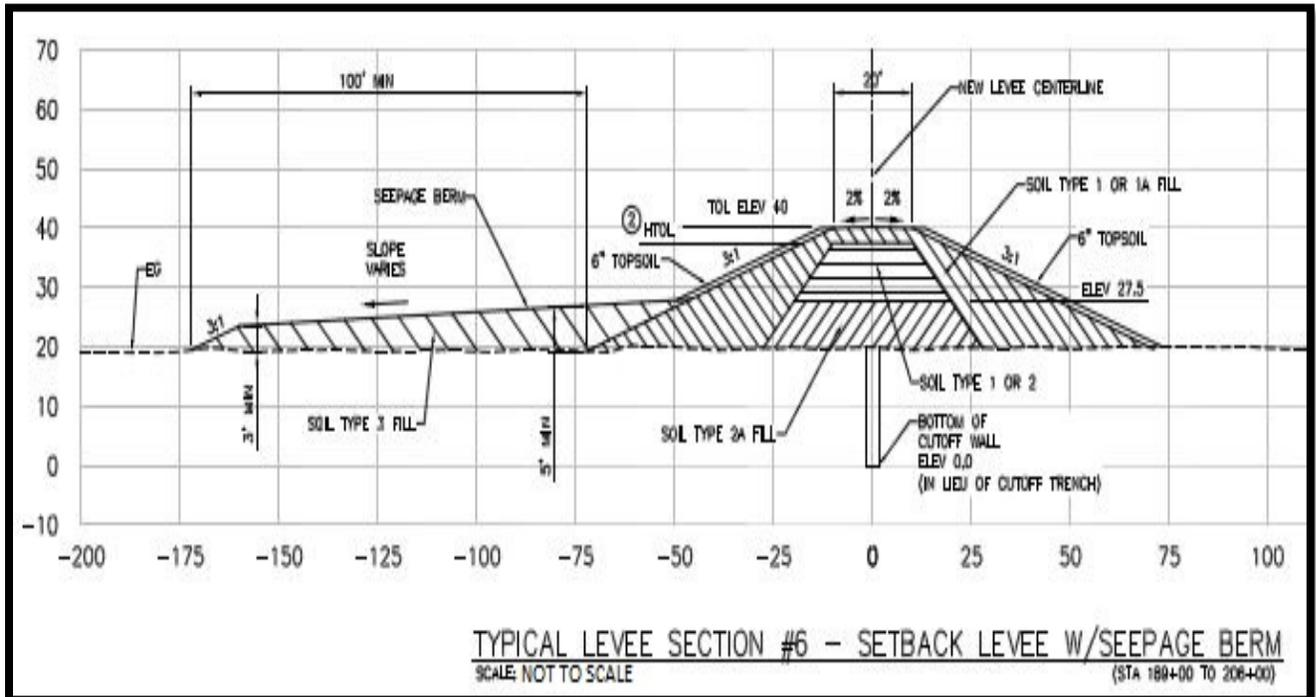

Figure 19: Setback Levee with Seepage Berm

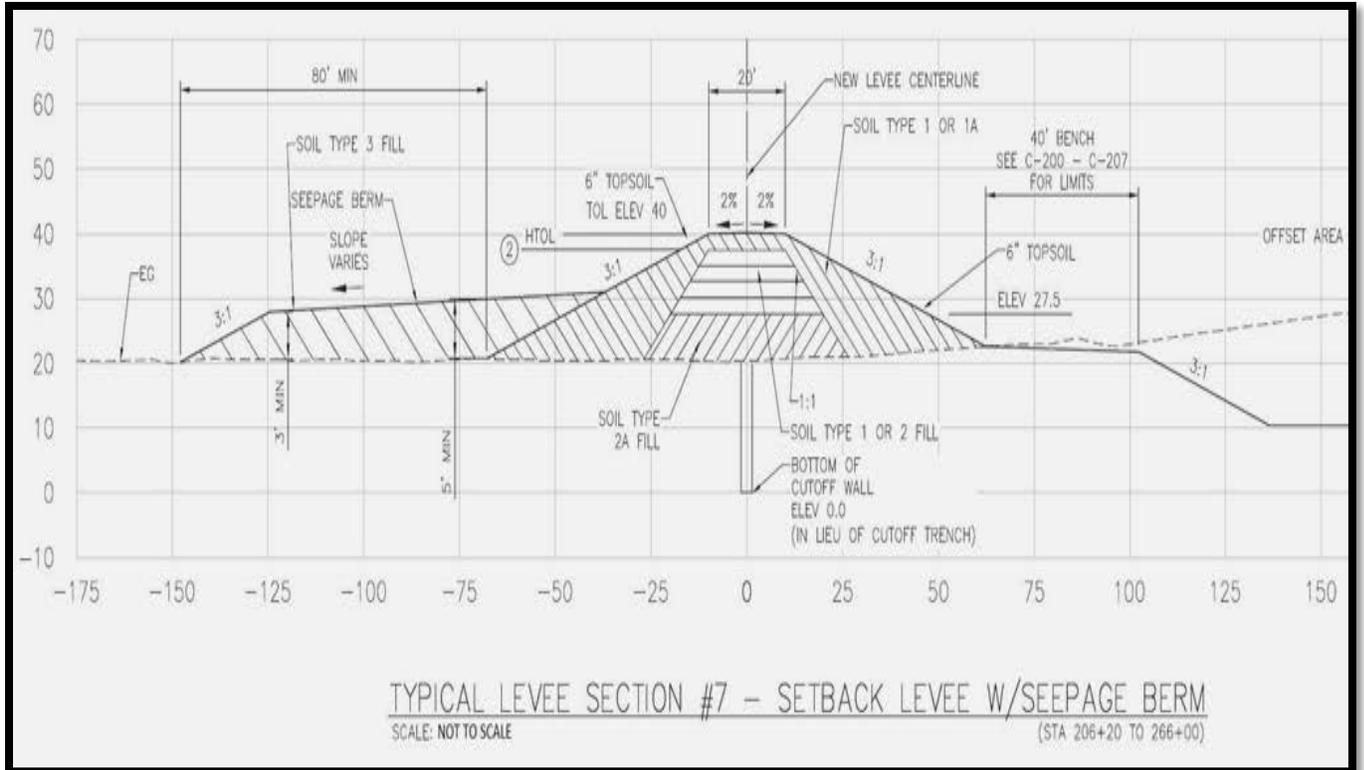

Figure 20: Setback Levee with Seepage Berm

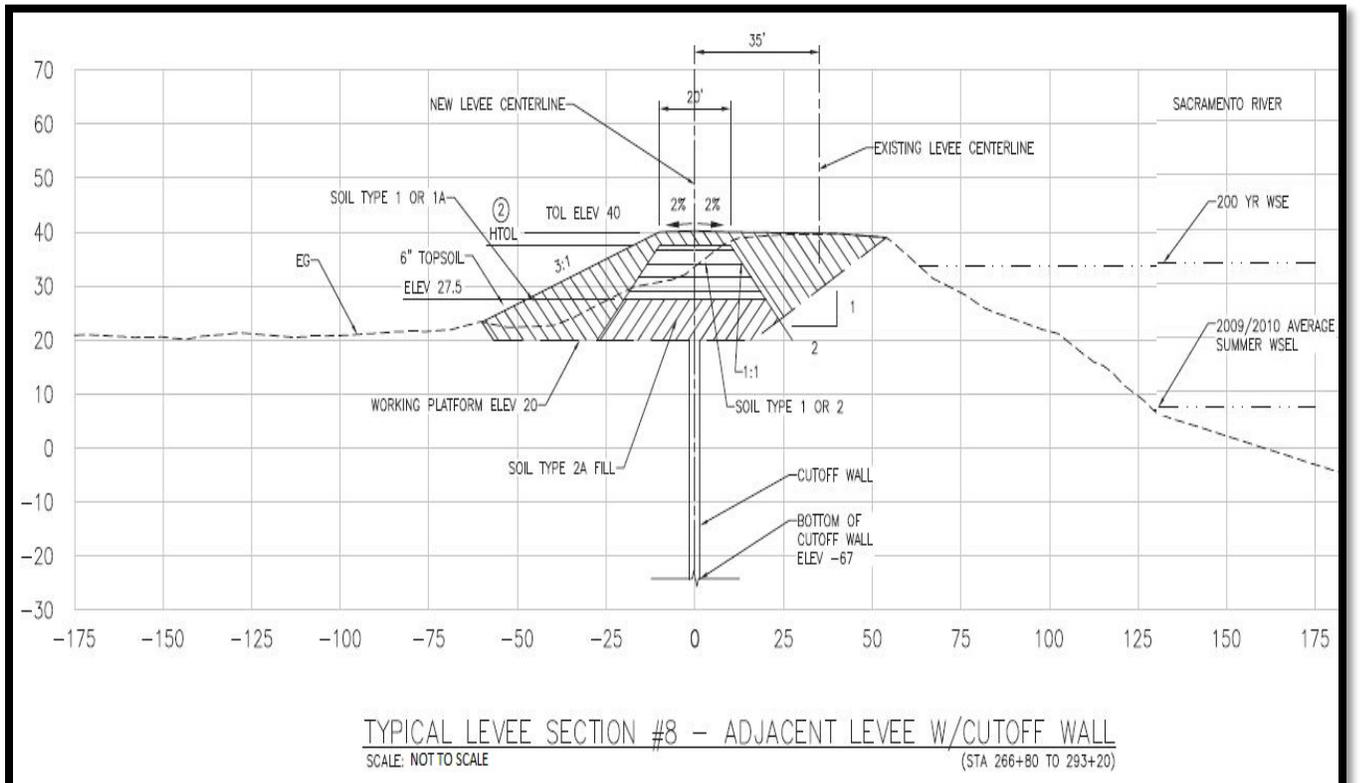
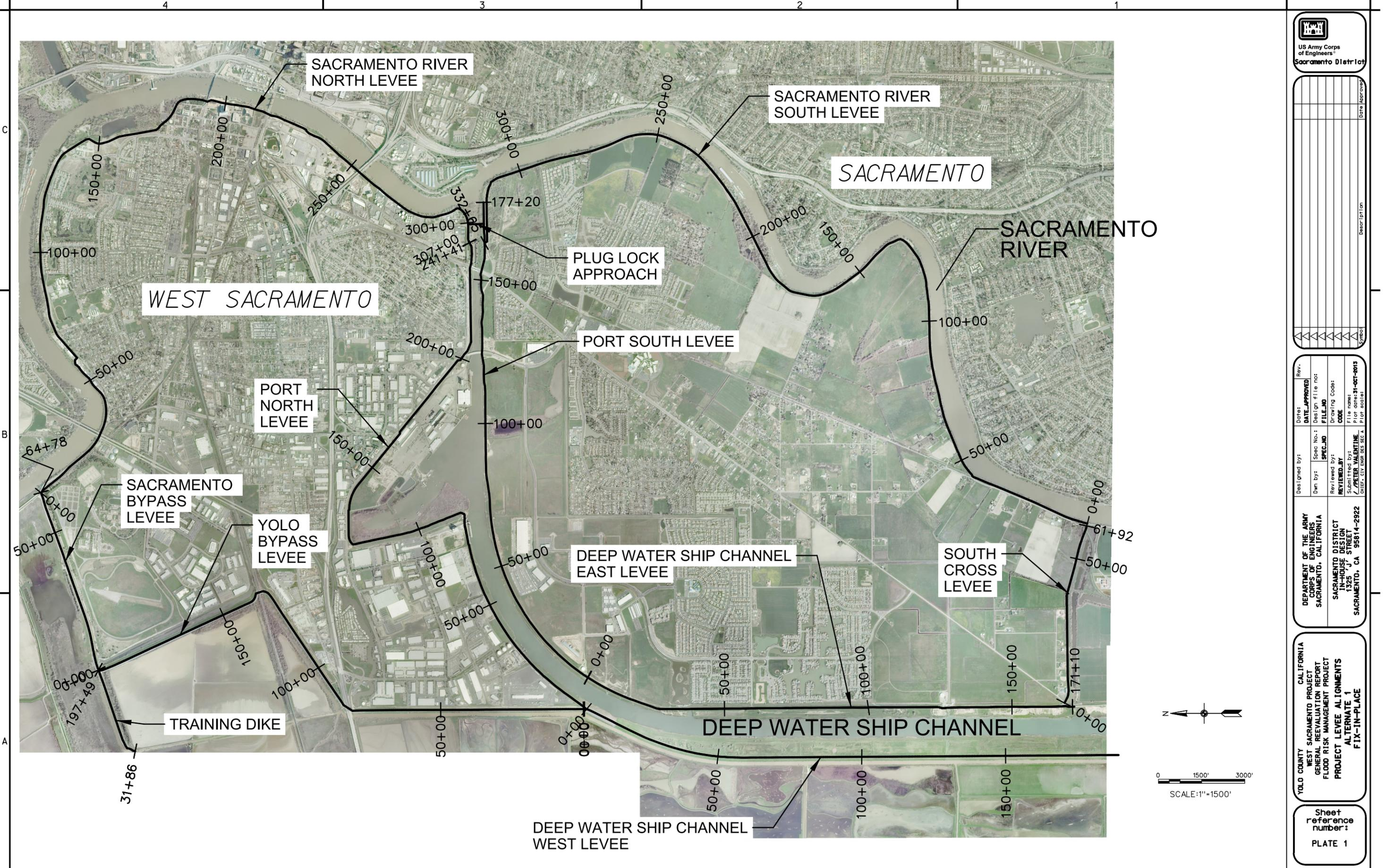

Figure 21: Adjacent Levee with Cutoff Wall

**ATTACHMENT 2 - PLATES**



Date:	DATE APPROVED	Rev.
Desig'd by:	Spec No.:	Design File no:
Dwn by:	SPEC. NO.	FILE. NO.
Reviewed by:	REVIEWED BY	Drawing Code:
Submitted by:	PETER VALENTINE	File name:
DATE: CIV. ENG. DES. SEC. A	SACRAMENTO, CA 95814-2922	Plot date: 31-OCT-2013
		Plot scale:

DEPARTMENT OF THE ARMY CORPS OF ENGINEERS SACRAMENTO, CALIFORNIA	DEPARTMENT OF THE ARMY CORPS OF ENGINEERS SACRAMENTO DISTRICT IN-HOUSE DESIGN 1325 J STREET SACRAMENTO, CA 95814-2922
--	--

CALIFORNIA  
WEST SACRAMENTO PROJECT  
GENERAL REEVALUATION REPORT  
FLOOD RISK MANAGEMENT PROJECT  
PROJECT LEVEE ALIGNMENTS  
ALTERNATE 1  
FIX-IN-PLACE

Sheet  
reference  
number:  
PLATE 1



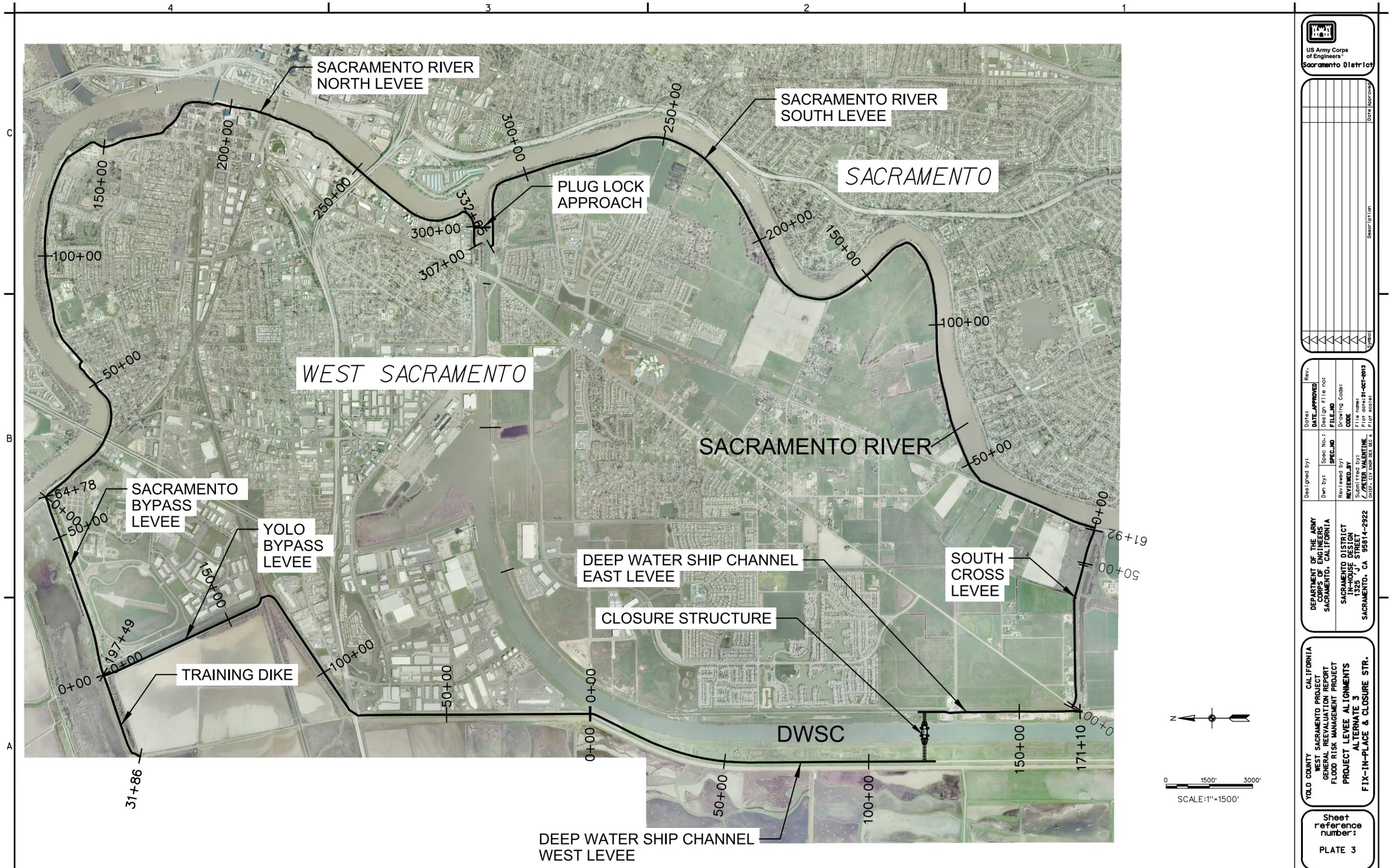

Rev.	Date	By	Spec No.	File No.	File Name

Designed by:	DATE APPROVED	Rev.
Dwn by:	FILE NO	Design file no:
Reviewed by:	CODE	Drawing Code:
Submitted by:	FILE NAME	File name:
		Plot date: 31-OCT-2013
		Plot scale:

DEPARTMENT OF THE ARMY  
CORPS OF ENGINEERS  
SACRAMENTO, CALIFORNIA

SACRAMENTO DISTRICT  
IN-HOUSE DESIGN  
1325 J STREET  
SACRAMENTO, CA 95814-2922

CALIFORNIA  
WEST SACRAMENTO PROJECT  
GENERAL REEVALUATION REPORT  
FLOOD RISK MANAGEMENT PROJECT  
PROJECT LEVEE ALIGNMENTS  
ALTERNATE 3  
FIX-IN-PLACE & CLOSURE STR.

Sheet reference number:  
PLATE 3

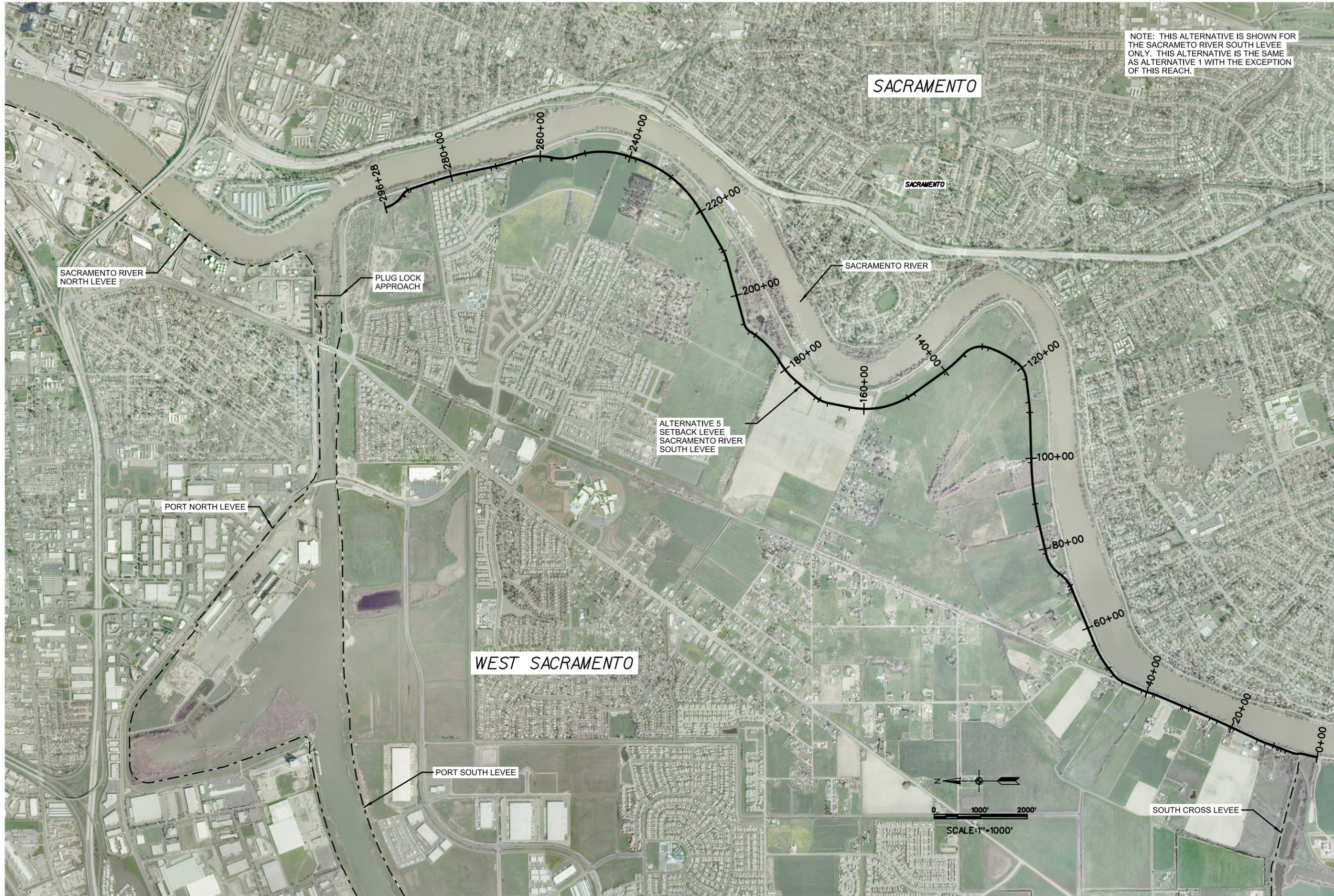

NOTE: THIS ALTERNATIVE IS SHOWN FOR THE SACRAMENTO RIVER SOUTH LEVEE ONLY. THIS ALTERNATIVE IS THE SAME AS ALTERNATIVE 1 WITH THE EXCEPTION OF THIS REACH.



Date	Rev.
DATE-APPROVED	FILE_NO
DESIGN FILE NO	DRAWING CODE
FILE_NO	CODE
FILE_NO	FILE_NAME
FILE_NO	PLOT DATE: 31-OCT-2013
FILE_NO	PLOT SCALE:

DESIGNED BY:	SPEC NO.:	DATE-APPROVED:	REV.
DWN BY:	SPEC_NO	DESIGN FILE NO:	FILE_NO
REVIEWED BY:	REVIEWED BY:	DRAWING CODE:	DRAWING CODE
SUBMITTED BY:	REVIEWED BY:	FILE NAME:	FILE_NAME
/PETER VALENTINE	/PETER VALENTINE	PLOT DATE: 31-OCT-2013	PLOT DATE: 31-OCT-2013
DISTRICT CIVIL ENGINEER	DISTRICT CIVIL ENGINEER	PLOT SCALE:	PLOT SCALE:

CALIFORNIA  
 WEST SACRAMENTO PROJECT  
 GENERAL REEVALUATION REPORT  
 FLOOD RISK MANAGEMENT PROJECT  
 ALTERNATIVE 5  
 ALIGNMENT SETBACK LEVEE

Sheet  
 reference  
 number:  
 PLATE 4